

RoHS Compliant

Serial ATA Flash Drive

Specifications for SAFD 254-M

February 10, 2010

Version 1.8



Apacer Technology Inc.

4th Fl., 75 Xintai 5th Rd., Sec.1, Hsichih, Taipei Hsien 221, Taiwan

Tel: +886-2-2698-2888 Fax: +886-2-2698-2889

www.apacer.com

Features:

- **Standard Serial ATA 2.5 (Gen. 2)**
 - Serial ATA 2.5 (Gen. 2)
 - SATA II, 3.0 Gbps
 - ATA-compatible command set
- **Capacities**
 - 8, 16, 32, 64, 128, 256 GB
- **Performance**
 - Burst read/write: 300 MB/sec
 - Sustained read: up to 155 MB/sec
 - Sustained write: up to 100 MB/sec
- **Intelligent endurance design**
 - Built-in hardware ECC, enabling up to 8/15 bit correction per 512 bytes
 - Global wear-leveling scheme together with dynamical block allocation to significantly increase the lifetime of a flash device and optimize the disk performance
 - Flash bad-block management
 - S.M.A.R.T. technology
 - Power Failure Management
 - Quick Erase
- **NAND Flash Type: MLC**
- **Zero power data retention**
 - No battery required for data storage
- **Temperature**
 - 0°C to 70°C for operating
 - -40°C to 100°C for storage
- **Supply voltage**
 - 5.0 V \pm 5%
- **Low power consumption**
 - Active mode: 400 mA (5.0 V)
 - Idle mode: 140 mA (5.0 V)
- **Form factor**
 - 2.5 inch
- **Connector**
 - 7-pin SATA male connector
 - 15-pin SATA power connector
- **RoHS compliant**
-

Table of Contents

1. Product Description	3
1.1 Introduction	3
1.2 Functional Block Diagram	3
1.3 ATA Mode Support	4
1.4 Capacity Specification	4
1.5 Performance	4
1.6 Pin Assignments	5
2. Software Interface	6
2.1 Command Set	6
2.2 S.M.A.R.T. Technology	8
3. Flash Management	9
3.1 Error Correction/Detection	9
3.2 Bad Block Management	9
3.3 Wear Leveling	9
3.4 Power Failure Management	9
3.5 Quick Erase	9
4. Environmental Specifications	10
4.1 Environments	10
4.2 Mean Time Between Failures (MTBF)	10
4.3 Certification and Compliance	10
5. Electrical Characteristics	11
5.1 Operating Voltage	11
5.2 Power Consumption	11
6. Physical Characteristics	12
7. Product Ordering Information	13
7.1 Product Code Designations	13
7.2 Valid Combinations	14

1. Product Description

1.1 Introduction

Apacer's Serial ATA Flash Drive (SAFD) is a solid-state disk (SSD) drive that contains a controller, embedded firmware, and flash media along with a male connector. Using multi-level cell (MLC) NAND flash memory devices, the SAFD drive interfaces with the host allowing data to be seamlessly transferred between the host and the flash devices.

The SAFD 254 drive is designed with a single-chip controller, offering capacities of up to 256 gigabytes and providing full support for the SATA II high-speed interface standard. It can operate at sustained access rates of up to 100 megabytes per second, which is much faster than any other solid-state or traditional SATA drive currently available on the market.

In addition to buffer management through dynamical allocation, the SAFD 254 adopts the Apacer-specific static wear-leveling scheme to allow uniform use of all storage blocks, ensuring that the lifetime of a flash media can be significantly increased and the disk performance is optimized as well. The SAFD 254 provides the S.M.A.R.T. feature that follows the SATA Rev. 2.5, ATA/ATAPI-7 specifications and uses the standard SMART command B0h to read data from the drive. This feature protects the user from unscheduled downtime by monitoring and storing critical drive performance.

1.2 Functional Block Diagram

The SAFD 254 drive includes a single-chip SATA II Controller and the flash media, as well as the SATA standard interface. The controller integrates the flash management unit with the controller itself to support multi-channel, multi-bank flash arrays. Figure 1-1 shows the functional block diagram.

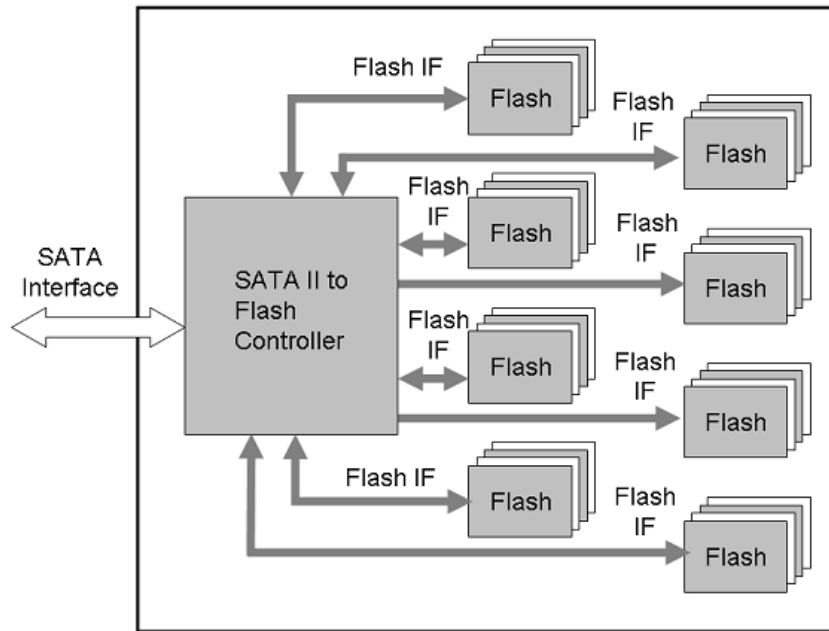

Figure 1-1 Apacer SAFD 254 block diagram

1.3 ATA Mode Support

The SAFD 254 provides ATA mode support as follows:

- Up to PIO mode-4
- Up to Multiword DMA mode-2
- Up to UDMA mode-5

1.4 Capacity Specification

Capacity specification of the SAFD product family is available as shown in Table 1-1. It lists the specific capacity, the default numbers of logical cylinders and heads, and the number of logical sectors per track for each product line.

Table 1-1 Capacity specification

Capacity	Total Bytes	Cylinders	Heads	Sectors	Max LBA
8 GB	8,061,419,520	15260	16	63	15,744,960
16 GB	16,139,681,792	16383	16	63	31,522,816 ¹
32 GB	32,296,140,800	16383	16	63	63,078,400 ¹
64 GB	64,609,058,816	16383	16	63	126,189,568 ¹
128 GB	129,234,894,848	16383	16	63	252,411,904 ¹
256 GB	258,486,566,912	16383	16	63	504,856,576 ¹

¹ Cylinders, heads or sectors are not applicable for these capacities. Only LBA addressing applies.

1.5 Performance

Performance of the SAFD is shown in Table 1-2.

Table 1-2 Performance specification

Capacity \ Performance	8GB	16GB	32GB	64GB	128GB	256GB
Sustained Read (MB/s)	128	155	163	152	150	154
Sustained Write (MB/s)	32	50	53	89	90	98

1.6 Pin Assignments

Figure 1-2 illustrates the SAFD signal pins, and Table 1-3 describes its power pins.

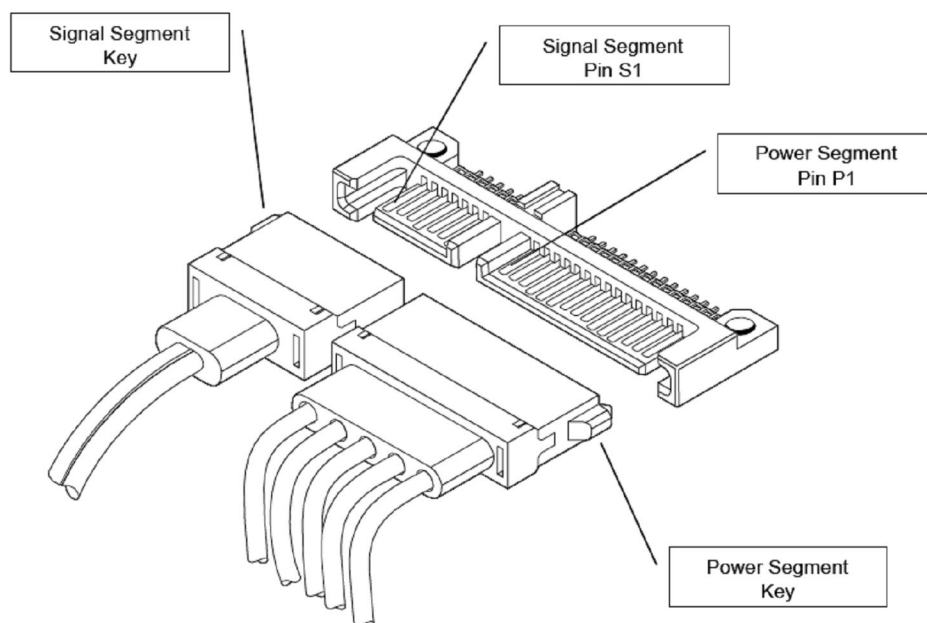

Table 1-3: Signal segment

Name	Type	Description
S1	GND	
S2	RxP	Serial Data Receiver
S3	RxN	
S4	GND	
S5	TxN	Serial Data Transmitter
S6	TxP	
S7	GND	

Table 1-4: Power segment

Pin	Signal/Description
P1	Not used (3.3V)
P2	Not used (3.3V)
P3	Not used (3.3V)
P4	Ground
P5	Ground
P6	Ground
P7	5V Pre-Charge
P8	5V
P9	5V
P10	Ground
P11	Ground
P12	Ground
P13	Not used (12V Pre-Charge)
P14	Not used (12V)
P15	Not used (12V)

2. Software Interface

2.1 Command Set

Table 2-1 summarizes the ATA commands supported by the SAFD254.

Table 2-1: Command set (1 of 2)

Command	Code	FR ¹	SC ²	SN ³	CY ⁴	DH ⁵	LBA ⁶
Check-Power-Mode	E5H	-	-	-	-	D ⁸	-
Execute-Drive-Diagnostic	90H	-	-	-	-	D	-
Flush-Cache	E7H	-	-	-	-	D	-
Identify-Drive	ECH	-	-	-	-	D	-
Idle	E3H	-	Y	-	-	D	-
Idle-Immediate	E1H	-	-	-	-	D	-
Initialize-Drive-Parameters	91H	-	Y	-	-	Y	-
Read-DMA	C8H or C9H	-	Y	Y	Y	Y	Y
Read-Multiple	C4H	-	Y	Y	Y	Y	Y
Read-Sector(s)	20H or 21H	-	Y	Y	Y	Y	Y
Read-Verify-Sector(s)	40H or 41H	-	Y	Y	Y	Y	Y
Recalibrate	10H	-	-	-	-	D	-
Security-Disable-Password	F6H	-	-	-	-	D	-
Security-Erase-Prepare	F3H	-	-	-	-	D	-
Security-Erase-Unit	F4H	-	-	-	-	D	-
Security-Freeze-Lock	F5H	-	-	-	-	D	-
Security-Set-Password	F1H	-	-	-	-	D	-
Security-Unlock	F2H	-	-	-	-	D	-
Seek	7XH	-	-	-	Y	Y	-
Set-Features	EFH	Y ⁷	-	-	-	D	-

Table 2-1: Command set (2 of 2)

Command	Code	FR ¹	SC ²	SN ³	CY ⁴	DH ⁵	LBA ⁶
Set-Multiple-Mode	C6H	-	Y	-	-	D	-
Sleep	E6H	-	-	-	-	D	-
SMART	B0H	Y	Y	Y	Y	D	
Standby	E2H	-	-	-	-	D	-
Standby-Immediate	E0H	-	-	-	-	D	-
Write-DMA	CAH	-	Y	Y	Y	Y	Y
Write-Multiple	C5H	-	Y	Y	Y	Y	Y
Write-Sector(s)	30H	-	Y	Y	Y	Y	Y

1. FR - Features register
2. SC - Sector Count register
3. SN - Sector Number register
4. CY - Cylinder registers
5. DH - Drive/Head register
6. LBA - Logical Block Address mode supported (see command descriptions for use)
7. Y - The register contains a valid parameter for this command.
8. For the Drive/Head register:
 Y means both the SAFD and Head parameters are used
 D means only the SAFD parameter is valid and not the Head parameter

2.2 S.M.A.R.T. Technology

S.M.A.R.T. is an acronym for Self-Monitoring, Analysis and Reporting Technology, an open standard allowing disk drives to automatically monitor their own health and report potential problems. It protects the user from unscheduled downtime by monitoring and storing critical drive performance and calibration parameters. Ideally, this should allow taking proactive actions to prevent impending drive failure.

Apacer SAFD254 uses the standard SMART command B0h to read data from the drive for SMART feature as the SATA Rev.2.6 ATA/ATAPI-7 specifications. Based on the SFF-8035i Rev. 2.0 specifications, Apacer SMART defines 3 vendor-specified SMART Attribute IDs (E5h, EAh-EBh, and E8h) in the SAFD254. They represent Flash ID, maximum erase count, average erase count, good block count, free-list block count, and firmware version information. When the Apacer SMART Utility running on the host, it analyzes and reports the disk status to the host before the SAFD254 is in critical condition.

3. Flash Management

3.1 Error Correction/Detection

The SAFD254 implements a hardware ECC scheme, based on the BCH algorithm. It can detect and correct up to 8 bits or 15 bits error in 512 bytes.

3.2 Bad Block Management

Although bad blocks on the flash media are already identified by the flash manufacturer, they can also be accumulated over time during operation. The SAFD254's controller maintains a table that lists those normal blocks with disk data, the free blocks for wear leveling, and bad blocks with errors. When a normal block is detected broken, it is replaced with a free block and listed as a bad block. When a free block is detected broken, it is then removed from the free block list and marked as a bad block.

During device operation, this ensures that newly accumulated bad blocks are transparent to the host. The device will stop file write service once there are only two free blocks left such that the read function is still available for copying the files from the disk into another.

3.3 Wear Leveling

The NAND flash devices are limited by a certain number of write cycles. When using a FAT-based file system, frequent FAT table updates are required. If some area on the flash wears out faster than others, it would significantly reduce the lifetime of the whole SSD, even if the erase counts of others are far from the write cycle limit. Thus, if the write cycles can be distributed evenly across the media, the lifetime of the media can be prolonged significantly. This scheme is called wear leveling.

Apacer's wear-leveling scheme is achieved both via buffer management and Apacer-specific static wear leveling. They both ensure that the lifetime of the flash media can be increased, and the disk access performance is optimized as well.

3.4 Power Failure Management

The Low Power Detection on the controller initiates crucial data saving before the power supplied to the device is too low. This feature prevents the device from crash and ensures data integrity during an unexpected power-off.

3.5 Quick Erase

Accomplished by the Secure Erase (SE) command, which added to the open ANSI standards that control disk drives, "Quick Erase" is built into the disk drive itself and thus far less susceptible to malicious software attacks than external software utilities. It is a positive easy-to-use data destroy command, amounting to electronic data shredding. Executing the command causes a drive to internally completely erase all possible user data. This command is carried out within disk drives, so no additional software is required. Once executed, neither data nor the erase counter on the device would be recoverable, which blurs the accuracy of device lifespan. The process to erase will not be stopped until finished while encountering power failure, and will be continued when power is back on.

4. Environmental Specifications

4.1 Environments

The SAFD 254 environmental specifications follow the US Military Standard MIL-STD-810F, as shown in Table 4-1.

Table 4-1 SAFD 254 environmental specifications

Environment	Specification
Temperature	0°C to 70°C (Operating – Standard)
	-40°C to 100°C (Non-operating)
Humidity	5% to 95% RH (Non-condensing)
Vibration	Sine wave: 5~55~5 Hz (X, Y, Z) Random: 10-2000 Hz, 16.3 G (X, Y, Z)
Shock - Operating	Acceleration: 1,500 G, 0.5 ms Peak acceleration: 50 G, 11 ms
Altitude	80,000 ft

4.2 Mean Time Between Failures (MTBF)

Mean Time Between Failures (MTBF) is predicted based on reliability data for the individual components in the SAFD drive. Although many component MTBFs are given in databases and often these values are not really accurate, the prediction result for the SAFD 254 is more than 1,000,000 hours.

4.3 Certification and Compliance

The SAFD 254 drive complies with the following standards:

- CE – EN55022/55024
- FCC 47CFR Part15 Class B
- RoHS
- MIL-STD-810F
- SATA II (SATA Rev. 2.5)
- Up to ATA/ATAPI-7 (including S.M.A.R.T.)

5. Electrical Characteristics

5.1 Operating Voltage

Table 5-1 lists the supply voltage for SAFD 254.

Table 5-1 SAFD 254 operating voltage

Parameter	Conditions
Supply voltage	5.0 V \pm 10% (4.5-5.5 V)

5.2 Power Consumption

Table 5-2 lists the SAFD 254 power consumption.

Table 5-2 SAFD 254 power consumption

Capacity	Read		Write		Idle mode	
	Current (Icc)	Watt	Current (Icc)	Watt	Current (Icc)	Watt
128GB	245mA	1.22 W	378mA	1.89 W	140mA	0.7 W

6. Physical Characteristics

Figure 6-1 illustrates the overall dimensions of the SAFD drive, as listed in Table 6-1.

Table 6-1 SAFD dimensions

Dimension	Millimeters (mm)
Height	9.30 ± 0.10
Width	69.85 ± 0.10
Length	100.00 ± 0.10

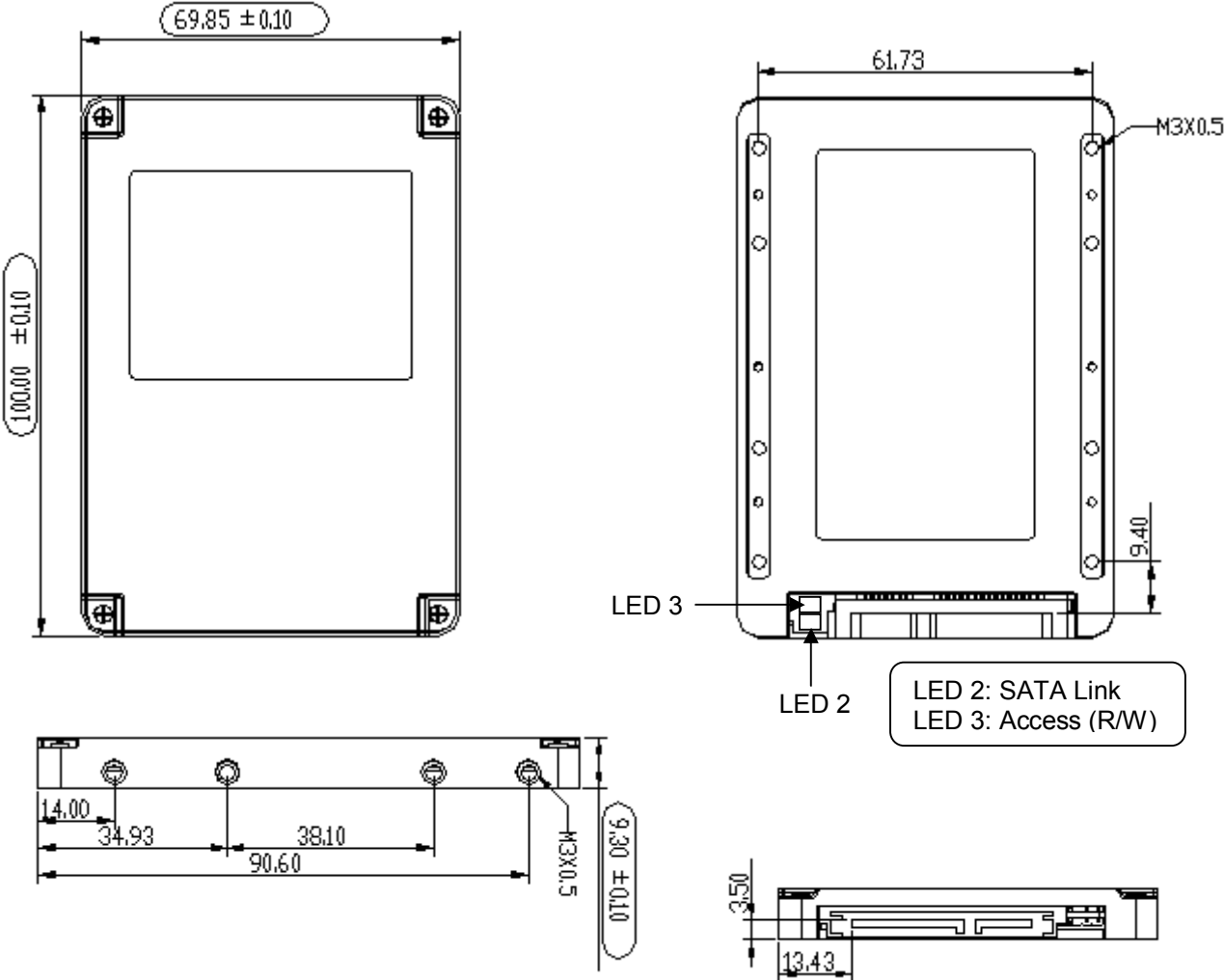
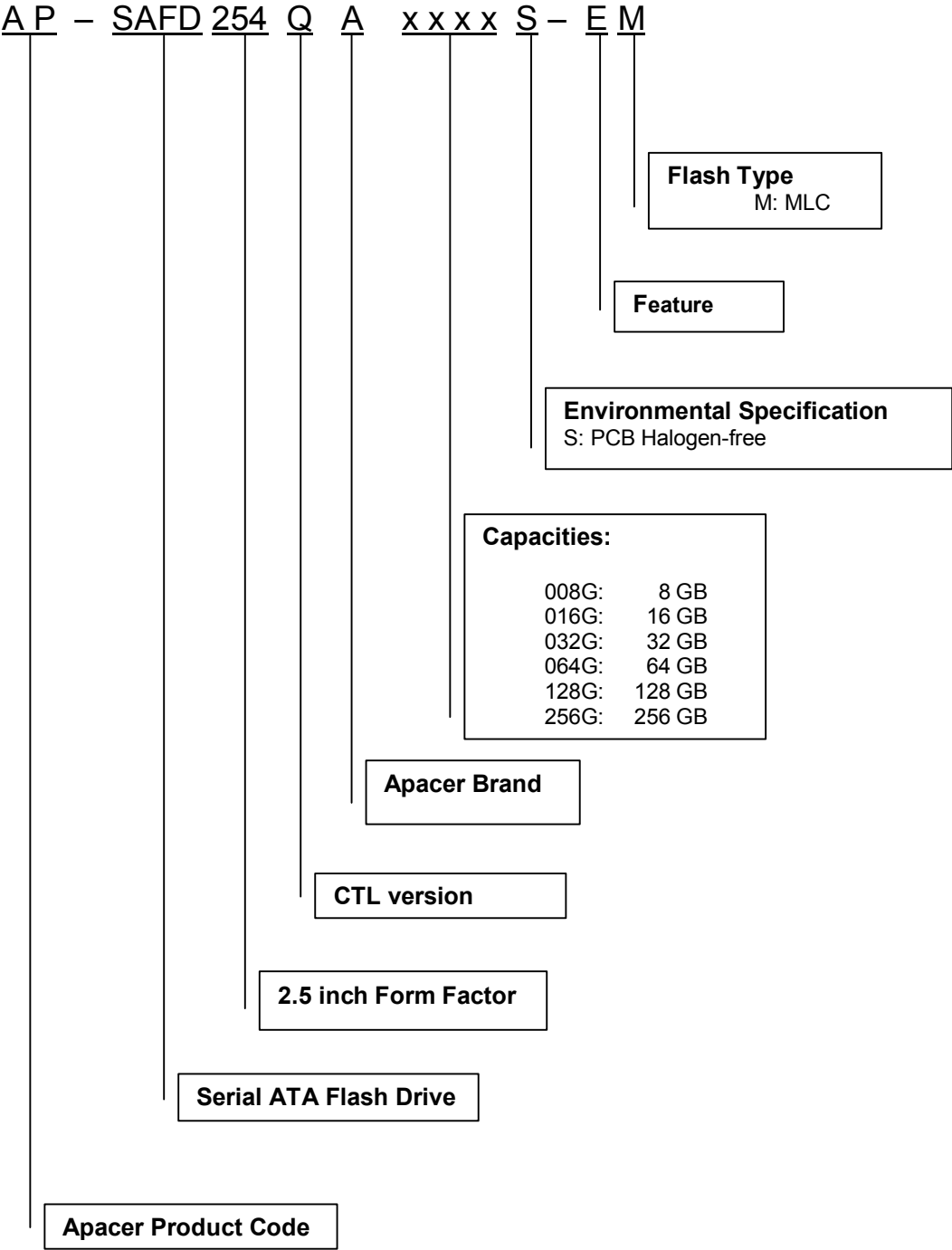

Figure 6-1. SAFD physical dimensions

Unit: mm

7. Product Ordering Information

7.1 Product Code Designations



7.2 Valid Combinations

Capacity	Model Number
8 GB	AP-SAFD254QA008GS-EM
16 GB	AP-SAFD254QA016GS-EM
32 GB	AP-SAFD254QA032GS-EM
64 GB	AP-SAFD254QA064GS-EM
128 GB	AP-SAFD254QA128GS-EM
256 GB	AP-SAFD254QA256GS-EM

Note: Valid combinations are those products in mass production or will be in mass production. Consult your Apacer sales representative to confirm availability of valid combinations and to determine availability of new combinations.

Revision History

Revision	Description	Date
0.1	Preliminary release	Nov. 24, 2008
0.2	Updated context	Dec. 3, 2008
0.3	Updated LED indications	Jan. 14, 2009
0.4	Updated ECC specification	Feb. 13, 2009
1.0	Official release	Feb. 20, 2009
1.1	Updated Power Segment Description	Mar. 12, 2009
1.2	Updated CHS values	Mar. 23, 2009
1.3	Updated valid combination wording	Mar. 24, 2009
1.4	Supplemented quick erase related information	Jun. 18, 2009
1.5	Added 256GB to capacity specification	Jun. 25, 2009
1.6	Updated feature item	Aug. 21, 2009
1.7	Updated product ordering information	Dec. 17, 2009
1.8	Updated MTBF figure	Feb. 10, 2010

Global Presence

Taiwan (Headquarters)	Apacer Technology Inc. 4 th Fl., 75 Xintai 5 th Rd., Sec.1 Hsichih, 221 Taipei Hsien Taiwan, R.O.C. Tel: +886-2-2698-2888 Fax: +886-2-2698-2889 amtsales@apacer.com
U.S.A.	Apacer Memory America, Inc. 386 Fairview Way, Suite102, Milpitas, CA 95035 Tel: 1-408-518-8699 Fax: 1-408-935-9611 sa@apacerus.com
Japan	Apacer Technology Corp. 5F, Matsura Bldg., Shiba, Minato-Ku Tokyo, 105-0014, Japan Tel: 81-3-5419-2668 Fax: 81-3-5419-0018 jpservices@apacer.com
Europe	Apacer Technology B.V. Europalaan 89 5232 BC 'S-Hertogenbosch The Netherlands Tel: 31-73-645-9620 Fax: 31-73-645-9629 sales@apacer.nl
China	Apacer Electronic (Shanghai) Co., Ltd 1301, No.251,Xiaomuqiao Road, Shanghai, 200032, China Tel: 86-21-5529-0222 Fax: 86-21-5206-6939 sales@apacer.com.cn
India	Apacer Technologies Pvt. Ltd. #143, 1st Floor, Raheja Arcade, 5th Block Kormangala Industrial Layout, Bangalore - 560095, India Tel: 91-80-4152-9061 sales_india@apacer.com