

RoHS Compliant

Serial ATA Flash Drive

Specifications for SAFD25M2-M

December 17, 2009

Version 1.6

Features:

- **Standard Serial ATA 2.5 (Gen. 2)**
 - Serial ATA 2.5 (Gen. 2)
 - SATA II , 3.0 Gbps
 - ATA-compatible command set
- **Capacities**
 - 4, 8, 16, 32, and 64 GB
- **Performance**
 - Burst read/write: 300 MB/sec
 - Sustained read: up to 95 MB/sec
 - Sustained write: up to 50 MB/sec*
- **Intelligent endurance design**
 - Built-in hardware BCH ECC, correcting 8-bit or 15-bit error per 512-byte data sector
 - Static wear-leveling scheme together with dynamical block allocation to significantly increase the lifetime of a flash device and optimize the disk performance
 - Flash bad-block management
 - S.M.A.R.T. technology
 - Power Failure Management
 - Quick Erase
- **NAND Flash Type: MLC**
- **Data integrity under power-cycling**
 - No battery required for data storage
- **Temperature**
 - 0°C to 70°C for operating
 - -40°C to 100°C for storage
- **Supply voltage**
 - 5.0 V \pm 5%
- **Low power consumption**
 - Active mode: 260 mA (5.0 V)
 - Idle mode: 130 mA (5.0 V)
- **Form factor**
 - 2.5 inch
- **Connector**
 - 7-pin SATA male connector
 - 15-pin SATA power connector
- **RoHS compliant**

*Based on 32GB models.

Table of Contents

1. Product Description	3
1.1 Introduction	3
1.2 Functional Block Diagram	3
1.3 ATA Mode Support.....	4
1.4 Capacity Specification	4
1.5 Performance	4
1.5 Pin Assignments	5
2. Software Interface	6
2.1 Command Set.....	6
2.2 S.M.A.R.T. Technology.....	8
3. Flash Management	9
3.1 Error Correction/Detection	9
3.2 Bad Block Management	9
3.3 Wear Leveling.....	9
3.4 Power Failure Management	9
3.5 Quick Erase	9
4. Environmental Specifications	10
4.1 Environments	10
5. Electrical Specification	11
6. Physical Characteristics	12
6.1 Dimension	12
7. Product Ordering Information	14
7.1 Product Code Designations	14
7.2 Valid Combinations	15

1. Product Description

1.1 Introduction

Apacer's Serial ATA Flash Drive (SAFD25M2) is a solid-state disk (SSD) drive that contains a controller, embedded firmware, and flash media along with a male connector. Using NAND flash memory devices, the SAFD25M2 drive interfaces with the host allowing data to be seamlessly transferred between the host and the flash devices.

The SAFD25M2 drive is designed with a single-chip controller, offering capacities of up to 64 gigabytes and providing full support for the SATA II high-speed interface standard. It can operate at sustained access rates of up to 95 megabytes per second, which is much faster than any other solid-state or traditional SATA drive currently available on the market.

In addition to buffer management through dynamical allocation, the SAFD25M2 adopts the static wear-leveling scheme to allow uniform use of all storage blocks, ensuring that the lifetime of a flash media can be significantly increased and the disk performance is optimized as well. The SAFD25M2 provides the S.M.A.R.T. feature complies to the SATA Rev.2.6, ATA/ATAPI-7 specifications and uses the standard SMART command B0h to read data from the drive. This feature protects the user from unscheduled downtime by monitoring and storing critical drive performance.

1.2 Functional Block Diagram

The SAFD25M2 drive includes a single-chip SATA II Controller and the flash media, as well as the SATA standard interface. The controller integrates the flash management unit with the controller itself to support multi-channel, multi-bank flash arrays. Figure 1-1 shows the functional block diagram.

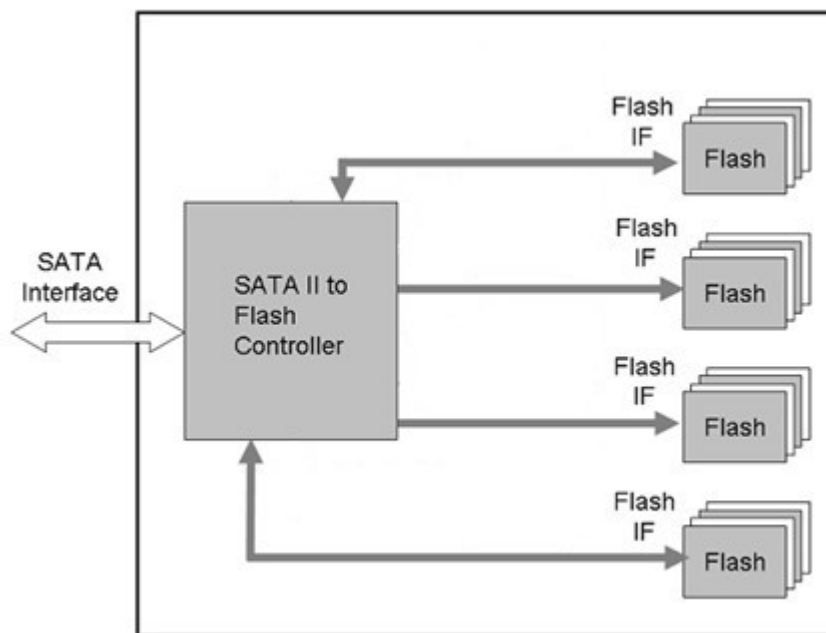

Figure 1-1 Apacer SAFD25M2 block diagram

1.3 ATA Mode Support

The SAFD25M2-M provides ATA mode support as follows:

- Up to PIO mode-4
- Up to Multiword DMA mode-2
- Up to UDMA mode-5

1.4 Capacity Specification

Capacity specification of the SAFD25M2-M product family is available as shown in Table 1-1. It lists the specific capacity, the default numbers of logical cylinders and heads, and the number of logical sectors per track for each product line.

Table 1-1 Capacity specification

Capacity	Total Bytes	Cylinders	Heads	Sectors	Max LBA
4 GB	4,021,936,128	7793	16	63	7,855,344
8 GB	8,061,419,520	15620	16	63	15,744,960
16 GB	16,139,681,792	16383	16	63	31,522,816 ¹
32 GB	32,296,140,800	16383	16	63	63,078,400 ¹
64 GB	64,609,058,816	16383	16	63	126,189,568 ¹

¹ Cylinders, heads or sectors are not applicable for these capacities. Only LBA addressing applies.

1.5 Performance

Performance of the SAFD25M2-M is shown in Table 1-2.

Table 1-2 Performance specification

Capacity \ Performance	4GB	8GB	16 GB	32 GB	64GB
Sustained read (MB/s)	75	94	94	93	94
Sustained write (MB/s)	17	25	25	51	50

1.5 Pin Assignments

Figure 1-2 illustrates pin assignments of Apacer SAFD25M2 pins, and Table 1-3 and Table 1-4 describe its signal segment and power segment, respectively.

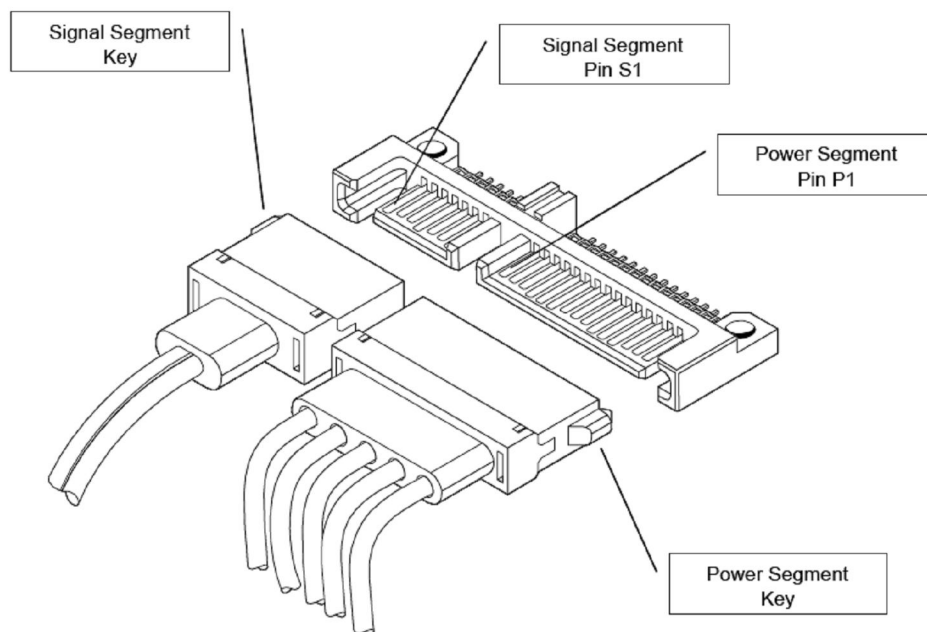

Figure 1-2 Apacer SAFD25M2 pin assignments

Table 1-3: Signal segment

Name	Type	Description
S1	GND	
S2	RxP	+ Differential Receive Signal
S3	RxN	- Differential Receive Signal
S4	GND	
S5	TxN	- Differential Transmit Signal
S6	TxP	+Differential Transmit Signal
S7	GND	

Table 1-4: Power segment

Pin	Signal/Description
P1	Not used (3.3V)
P2	Not used (3.3V)
P3	Not used (3.3V)
P4	Ground
P5	Ground
P6	Ground
P7	5V
P8	5V
P9	5V
P10	Ground
P11	Ground
P12	Ground
P13	Not used (12V)
P14	Not used (12V)
P15	Not used (12V)

2. Software Interface

2.1 Command Set

Table 2-1 summarizes the ATA commands supported by the SAFD25M2.

Table 2-1: Command set (1 of 2)

Command	Code	FR ¹	SC ²	SN ³	CY ⁴	DH ⁵	LBA ⁶
Check-Power-Mode	E5H	-	-	-	-	D ⁸	-
Execute-Drive-Diagnostic	90H	-	-	-	-	D	-
Flush-Cache	E7H	-	-	-	-	D	-
Identify-Drive	ECH	-	-	-	-	D	-
Idle	E3H	-	Y	-	-	D	-
Idle-Immediate	E1H	-	-	-	-	D	-
Initialize-Drive-Parameters	91H	-	Y	-	-	Y	-
Read-DMA	C8H or C9H	-	Y	Y	Y	Y	Y
Read-Multiple	C4H	-	Y	Y	Y	Y	Y
Read-Sector(s)	20H or 21H	-	Y	Y	Y	Y	Y
Read-Verify-Sector(s)	40H or 41H	-	Y	Y	Y	Y	Y
Recalibrate	10H	-	-	-	-	D	-
Security-Disable-Password	F6H	-	-	-	-	D	-
Security-Erase-Prepare	F3H	-	-	-	-	D	-
Security-Erase-Unit	F4H	-	-	-	-	D	-
Security-Freeze-Lock	F5H	-	-	-	-	D	-
Security-Set-Password	F1H	-	-	-	-	D	-
Security-Unlock	F2H	-	-	-	-	D	-
Seek	7XH	-	-	-	Y	Y	-
Set-Features	EFH	Y ⁷	-	-	-	D	-

Table 2-1: Command set (2 of 2)

Command	Code	FR ¹	SC ²	SN ³	CY ⁴	DH ⁵	LBA ⁶
Set-Multiple-Mode	C6H	-	Y	-	-	D	-
Sleep	E6H	-	-	-	-	D	-
SMART	B0H	Y	Y	Y	Y	D	
Standby	E2H	-	-	-	-	D	-
Standby-Immediate	E0H	-	-	-	-	D	-
Write-DMA	CAH	-	Y	Y	Y	Y	Y
Write-Multiple	C5H	-	Y	Y	Y	Y	Y
Write-Sector(s)	30H	-	Y	Y	Y	Y	Y

1. FR - Features register
2. SC - Sector Count register
3. SN - Sector Number register
4. CY - Cylinder registers
5. DH - Drive/Head register
6. LBA - Logical Block Address mode supported (see command descriptions for use)
7. Y - The register contains a valid parameter for this command.
8. For the Drive/Head register:
 Y means both the SAFD and Head parameters are used
 D means only the SAFD parameter is valid and not the Head parameter

2.2 S.M.A.R.T. Technology

S.M.A.R.T. is an acronym for Self-Monitoring, Analysis and Reporting Technology, an open standard allowing disk drives to automatically monitor their own health and report potential problems. It protects the user from unscheduled downtime by monitoring and storing critical drive performance and calibration parameters. Ideally, this should allow taking proactive actions to prevent impending drive failure.

Apacer SAFD25M2 uses the standard SMART command B0h to read data from the drive for SMART feature as the SATA Rev.2.6 ATA/ATAPI-7 specifications. Based on the SFF-8035i Rev. 2.0 specifications, Apacer SMART defines 3 vendor-specified SMART Attribute IDs (E5h, EAh-EBh, and E8h) in the SAFD25M2. They represent Flash ID, maximum erase count, average erase count, good block count, free-list block count, and firmware version information. When the Apacer SMART Utility running on the host, it analyzes and reports the disk status to the host before the SAFD25M2 is in critical condition.

3. Flash Management

3.1 Error Correction/Detection

The SAFD25M2 implements a hardware ECC scheme, based on the BCH algorithm. It can detect and correct up to 8 bits or 15 bits error in 512 bytes.

3.2 Bad Block Management

Although bad blocks on the flash media are already identified by the flash manufacturer, they can also be accumulated over time during operation. The SAFD25M2's controller maintains a table that lists those normal blocks with disk data, the free blocks for wear leveling, and bad blocks with errors. When a normal block is detected broken, it is replaced with a free block and listed as a bad block. When a free block is detected broken, it is then removed from the free block list and marked as a bad block.

During device operation, this ensures that newly accumulated bad blocks are transparent to the host. The device will stop file write service once there are only two free blocks left such that the read function is still available for copying the files from the disk into another.

3.3 Wear Leveling

The NAND flash devices are limited by a certain number of write cycles. When using a FAT-based file system, frequent FAT table updates are required. If some area on the flash wears out faster than others, it would significantly reduce the lifetime of the whole SSD, even if the erase counts of others are far from the write cycle limit. Thus, if the write cycles can be distributed evenly across the media, the lifetime of the media can be prolonged significantly. This scheme is called wear leveling.

Apacer's wear-leveling scheme is achieved both via buffer management and Apacer-specific static wear leveling. They both ensure that the lifetime of the flash media can be increased, and the disk access performance is optimized as well.

3.4 Power Failure Management

The Low Power Detection on the controller initiates crucial data saving before the power supplied to the device is too low. This feature prevents the device from crash and ensures data integrity during an unexpected power-off.

3.5 Quick Erase

Accomplished by the Secure Erase (SE) command, which added to the open ANSI standards that control disk drives, "Quick Erase" is built into the disk drive itself and thus far less susceptible to malicious software attacks than external software utilities. It is a positive easy-to-use data destroy command, amounting to electronic data shredding. Executing the command causes a drive to internally completely erase all possible user data. This command is carried out within disk drives, so no additional software is required. Once executed, neither data nor the erase counter on the device would be recoverable, which blurs the accuracy of device lifespan. The process to erase will not be stopped until finished while encountering power failure, and will be continued when power is back on.

4. Environmental Specifications

4.1 Environments

The SAFD25M2 environmental specifications follow the US Military Standard MIL-STD-810F, as shown in Table 4-1.

Table 4-1 SAFD25M2 environmental specifications (plan)

Environment	Specification
Temperature	0°C to 70°C (Operating – Standard)
	-40°C to 100°C (Non-operating)
Humidity	5% to 95% RH (Non-condensing)
Vibration	Sine wave: 5~55~5 Hz (X, Y, Z) Random: 10-2000 Hz, 16.3 G (X, Y, Z)
Shock	Acceleration: 1,500 G, 0.5 ms Peak acceleration: 50 G, 11 ms

5. Electrical Specification

Caution: Absolute Maximum Stress Ratings – (Applied conditions greater than those listed under “Absolute Maximum Stress Ratings” may cause permanent damage to the device. This is a stress rating only and functional operation of the device at these conditions or conditions greater than those defined in the operational sections of this data sheet is not implied. Exposure to absolute maximum stress rating conditions may affect device reliability.

Table 5-1: Operating voltage

Range	Ambient Temperature	5V
Standard	0°C to 70°C	4.5-5.5V

Table 5-2: Absolute maximum power pin stress ratings

Parameter	Symbol	Conditions
Input Power	V_{DD}	-0.3V min. to 6.5V max.
Voltage on any pin except V_{DD} with respect to GND	V	-0.5V min. to $V_{DD} + 0.5V$ max.

6. Physical Characteristics

6.1 Dimension

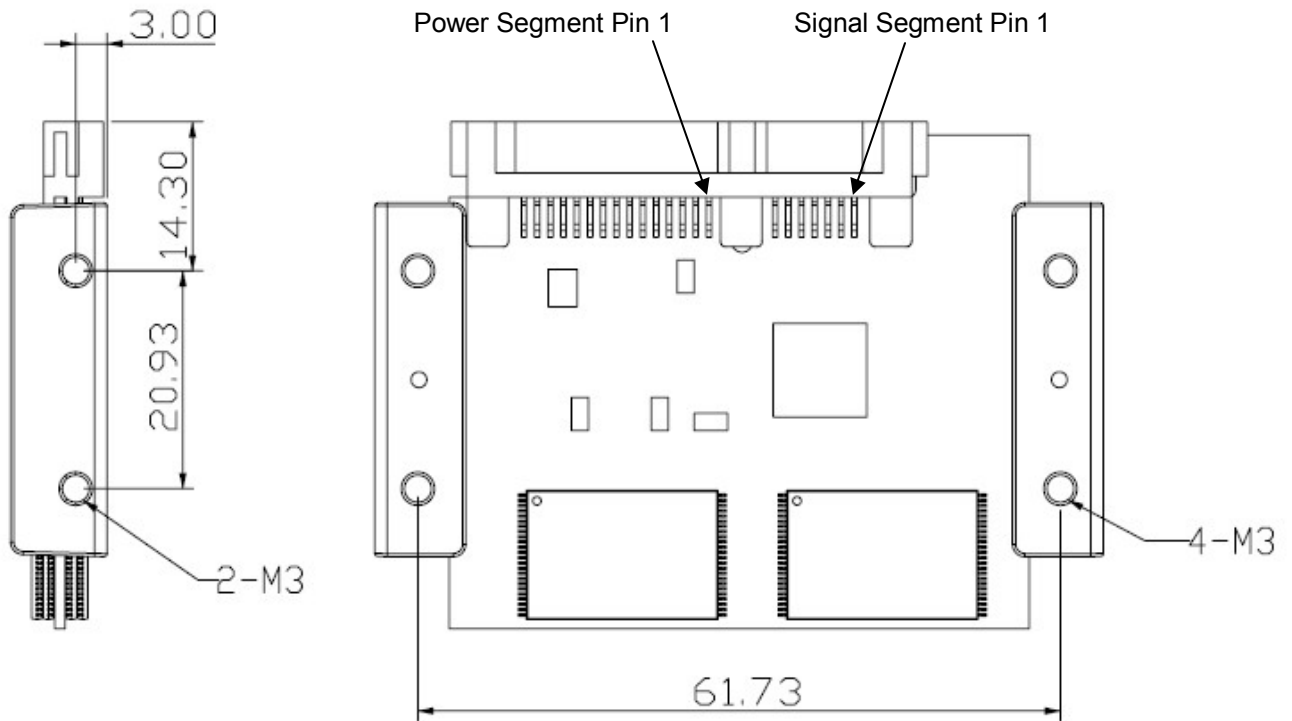

Unit: mm
Tolerance: $\pm 0.2\text{mm}$

Serial ATA Flash Drive
AP-SAFD25MPAxxxxS-EM

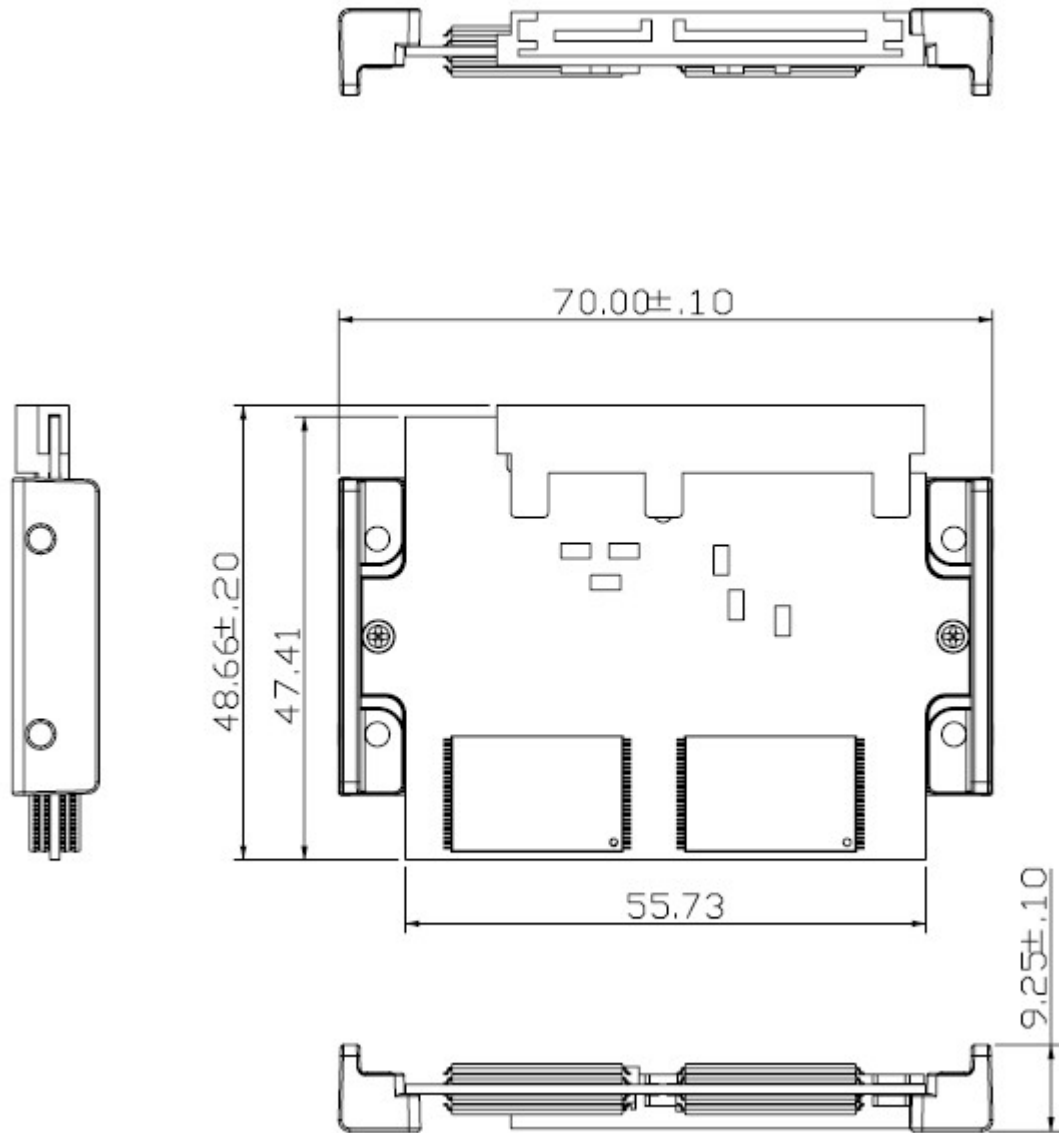

Unit: mm
Tolerance: ± 0.2 mm

7. Product Ordering Information

7.1 Product Code Designations

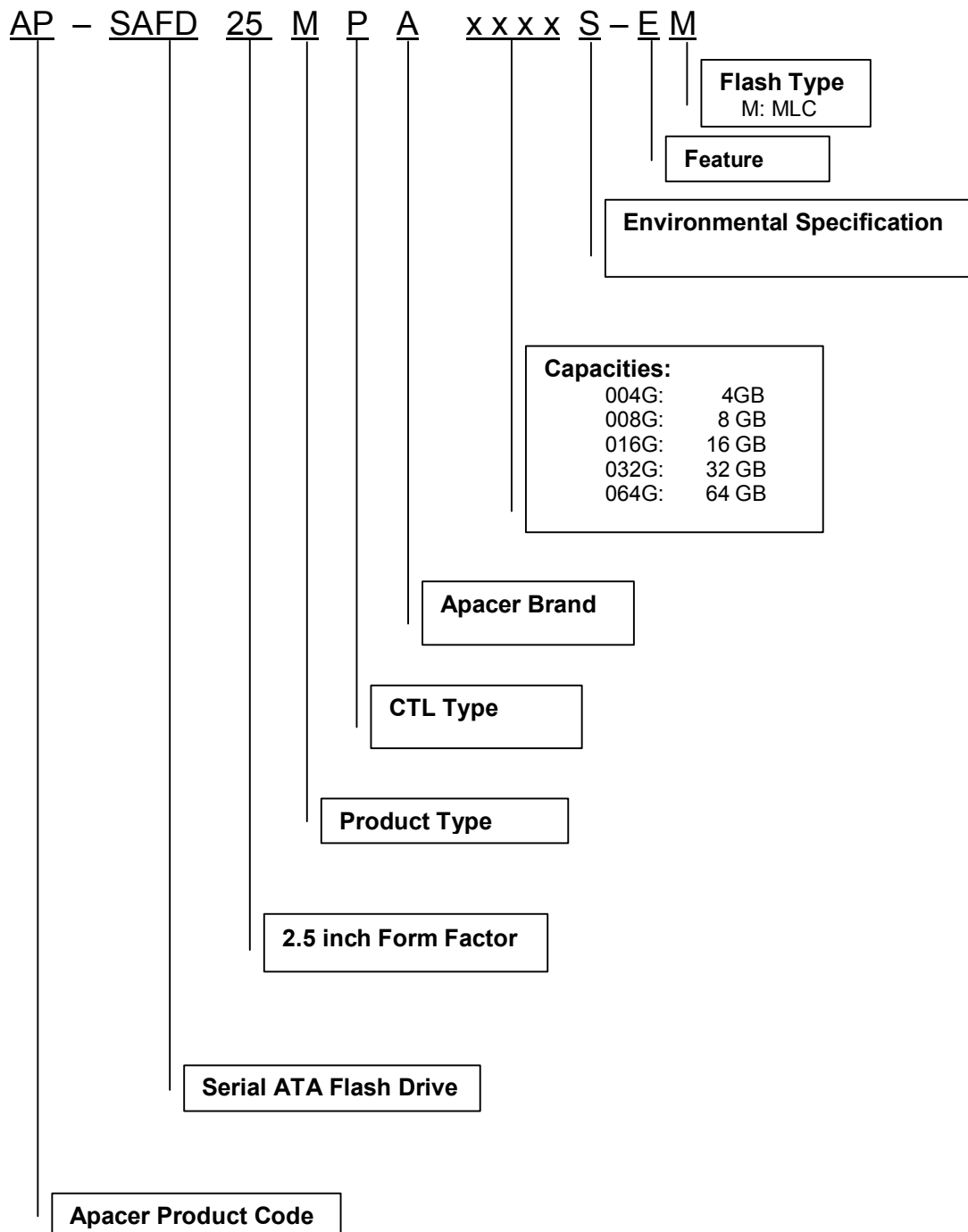

7.2 Valid Combinations

Capacity	Model Number
4GB	AP-SAFD25MPA004GS-EM
8GB	AP-SAFD25MPA008GS-EM
16GB	AP-SAFD25MPA016GS-EM
32GB	AP-SAFD25MPA032GS-EM
64GB	AP-SAFD25MPA064GS-EM

Note: Valid combinations are those products in mass production or will be in mass production. Consult your Apacer sales representative to confirm availability of valid combinations and to determine availability of new combinations.

Revision History

Revision	Date	Description	Remark
0.1	09/19/2008	Preliminary	
0.2	09/22/2008	Updated performance specification	
0.3	02/13/2009	Updated model names	
1.0	02/20/2009	Official release	
1.1	02/27/2009	Updated ECC algorithm	
1.2	03/23/2009	Updated capacity information	
1.3	03/24/2009	Updated valid combination wording	
1.4	04/27/2009	Updated CHS values	
1.5	06/18/2009	Supplemented quick erase related information	
1.6	12/07/2009	Updated product ordering information	

Global Presence

Taiwan (Headquarters)	Apacer Technology Inc. 4 th Fl., 75 Xintai 5 th Rd., Sec.1 Hsichih, 221 Taipei Hsien Taiwan, R.O.C. Tel: +886-2-2698-2888 Fax: +886-2-2698-2889 amtsales@apacer.com
U.S.A.	Apacer Memory America, Inc. 386 Fairview Way, Suite102, Milpitas, CA 95035 Tel: 1-408-518-8699 Fax: 1-408-935-9611 sa@apacerus.com
Japan	Apacer Technology Corp. 5F, Matsura Bldg., Shiba, Minato-Ku Tokyo, 105-0014, Japan Tel: 81-3-5419-2668 Fax: 81-3-5419-0018 jpservices@apacer.com
Europe	Apacer Technology B.V. Europalaan 89 5232 BC 'S-Hertogenbosch The Netherlands Tel: 31-73-645-9620 Fax: 31-73-645-9629 sales@apacer.nl
China	Apacer Electronic (Shanghai) Co., Ltd 1301, No.251,Xiaomuqiao Road, Shanghai, 200032, China Tel: 86-21-5529-0222 Fax: 86-21-5206-6939 sales@apacer.com.cn
India	Apacer Technologies Pvt. Ltd. #143, 1st Floor, Raheja Arcade, 5th Block Kormangala Industrial Layout, Bangalore - 560095, India Tel: 91-80-4152-9061 sales_india@apacer.com