

*RoHS Compliant*

# **SATA-Disk Chip II**

*Datasheet*

**January 18, 2011**

*Version 1.3*



***Apacer Technology Inc.***

4<sup>th</sup> Fl., 75 Hsin Tai Wu Rd., Sec.1 Hsichih, New Taipei City, Taiwan 221

Tel: +886-2-2698-2888 Fax: +886-2-2698-2889

[www.apacer.com](http://www.apacer.com)

## Features:

- **Standard Serial ATA 2.6 (Gen. 2)**
  - Serial ATA 2.6 (Gen. 2)
  - SATA II, 3.0 Gbps
  - ATA command set compatible
- **Connector type**
  - Standard 32/18 pin 600mil DIP
- **Low power consumption (typical)**
  - Supply voltage: 3.3V
  - Active mode: 300 mA
  - Idle mode: 197 mA
- **Performance**
  - Burst transfer rate: 300 MB/sec
  - Sustained read: 53 MB/sec
  - Sustained write: 45 MB/sec
- **Capacity**
  - 1, 2, 4, 8 GB
- **NAND Flash Type: SLC**
- **Temperature ranges**
  - Operation: -40°C to 85°C
  - Storage: -40°C to 100°C
- **Intelligent endurance design**
  - Built-in hardware BCH ECC, correcting 8-bit or 15-bit error per 512-byte data sector
  - Static Wear-Leveling scheme together with dynamical block allocation to significantly increase the lifetime of a flash device and optimize the disk performance
  - Flash Bad-Block Management
  - Power Failure Management
  - Quick Erase
  - S.M.A.R.T. technology
- **RoHS compliant**

## Table of Contents

<b>1. GENERAL DESCRIPTION .....</b>	<b>4</b>
<b>2. FUNCTIONAL BLOCK .....</b>	<b>5</b>
2.1 FUNCTIONAL SPECIFICATIONS.....	5
2.1.1 ATA Mode Support .....	5
2.1.2 Performance .....	5
2.1.3 Capacity Specification .....	6
2.2 ENVIRONMENTAL SPECIFICATIONS .....	6
<b>3. PIN ASSIGNMENTS .....</b>	<b>7</b>
3.1 32 PINS (16 X 2).....	7
3.2 18 PINS (7X2 + 2X2).....	8
<b>4. FLASH MANAGEMENT .....</b>	<b>9</b>
4.1 ERROR CORRECTION/DETECTION.....	9
4.2 BAD BLOCK MANAGEMENT .....	9
4.3 WEAR LEVELING .....	9
4.4 POWER FAILURE MANAGEMENT.....	9
4.5 QUICK ERASE .....	9
4.6 S.M.A.R.T. TECHNOLOGY.....	10
<b>5. SOFTWARE INTERFACE .....</b>	<b>11</b>
5.1 COMMAND SET .....	11
5.1.1 Check Power Mode (E5h) .....	13
5.1.2 Execute Diagnostics (90h) .....	13
5.1.3 Flush Cache (E7h) .....	13
5.1.4 Identify Device (ECh) .....	13
5.1.5 Idle (E3h).....	21
5.1.6 Idle Immediate (E1h).....	21
5.1.7 Initialize Drive Parameters (C8h) .....	21
5.1.8 Read DMA (C8h).....	22
5.1.9 Read Multiple (C4h) .....	22
5.1.10 Read Sector(s) (20h).....	22
5.1.11 Read Verify Sector(s) (40h).....	22
5.1.12 Recalibrate (10h).....	22
5.1.13 Security Disable Password (F6h).....	22
5.1.14 Security Erase Prepare (F3h).....	22
5.1.15 Security Erase Unit (F4h) .....	22
5.1.16 Security Freeze Lock (F5h).....	23
5.1.17 Security Set Password (F1h).....	23
5.1.18 Security Unlock (F2h).....	23
5.1.19 Seek (7xh) .....	23
5.1.20 Set Features (EFh).....	23
5.1.21 Set Multiple Mode (C6h).....	23
5.1.22 Sleep (E6h).....	23
5.1.23 SMART (B0h).....	24
5.1.24 Standby (E2h).....	26
5.1.25 Standby Immediate (E0h).....	26
5.1.26 Write DMA (CAh).....	27
5.1.27 Write Multiple (C5h).....	27

---

5.1.28 Write Sector(s) (30h).....	27
<b>6. PHYSICAL CHARACTERISTICS .....</b>	<b>28</b>
6.1 DIMENSION OF 32 PINS (16X2).....	28
6.2 DIMENSION OF 18 PINS (7X2 + 2X2).....	30
<b>7. PRODUCT ORDERING INFORMATION .....</b>	<b>32</b>
7.1 PRODUCT CODE DESIGNATIONS .....	32
7.2 VALID COMBINATIONS .....	33

---

## **1. General Description**

Apacer's SATA-Disk Chip (SDC) is a high performance, embedded flash memory data storage system. This product is designed for embedded flash storage applications with expanded functionality and is a cost-effective replacement for a conventional IDE hard disk drive. SDCs have a built-in micro-controller and file management firmware that communicates with SATA standard interfaces; therefore, SDCs do not require additional or proprietary host software such as Flash File System (FFS) and Memory Technology Driver (MTD) software. Packaged in a 600 mil 32 or 18 round pin DIP package for easy and cost-effective mounting to a system motherboard, SDCs are designed to work at 3.3 Volts and use a standard SATA driver that is part of all major operating systems such as Microsoft's Windows series, Apple's MAC OS family, and UNIX variants.

In addition to buffer management through dynamical allocation, SDC adopts the static wear-leveling scheme to allow uniform use of all storage blocks, ensuring that the lifetime of a flash media can be significantly increased and the disk performance is optimized as well. SDC provides the S.M.A.R.T. feature complies to the SATA Rev.2.6, ATA/ATAPI-7 specifications and uses the standard SMART command B0h to read data from the drive. This feature protects the user from unscheduled downtime by monitoring and storing critical drive performance.

## 2. Functional Block

The SATA-Disk Chip (SDC) includes the SATA and Flash Management controllers, and flash media, as well as the SATA standard interface. Figure 2-1 shows the functional block diagram.

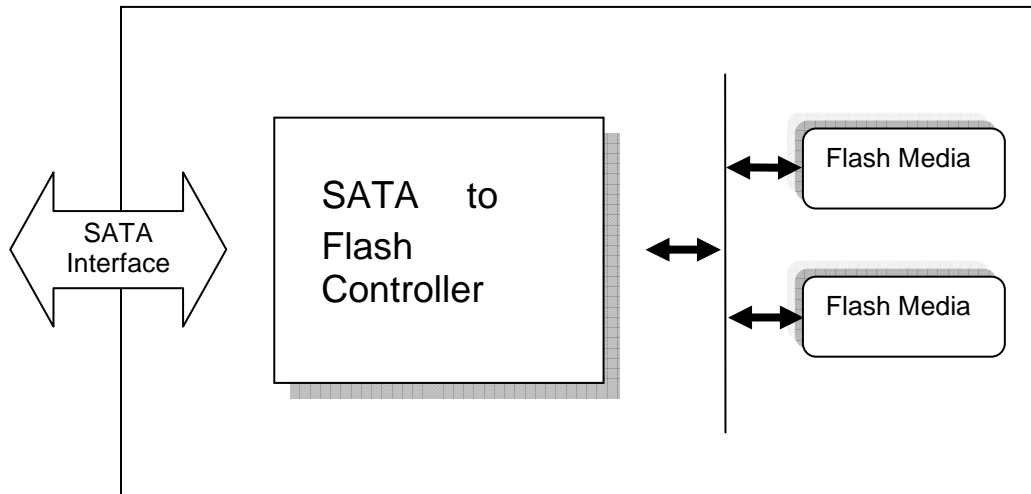

**Figure 2-1:** Functional block diagram

## 2.1 Functional Specifications

### 2.1.1 ATA Mode Support

The SATA-Disk Chip supports the following ATA operating modes:

- Supports up to PIO Mode-4
- Supports up to Multi-word DMA Mode-2
- Supports up to Ultra DMA Mode-5

### 2.1.2 Performance

Performance of SATA-Disk Chip is shown in table 2-1

**Table 2-1:** Performance specifications

Capacity \ Performance	1 GB	2 GB	4 GB	8 GB
<b>Sustained read (MB/s)</b>	27	27	53	53
<b>Sustained write (MB/s)</b>	12	22	45	45

Note: Performances vary from flash configurations.

### 2.1.3 Capacity Specification

Capacity specification of the SDC product family is available as shown in Table 2-2. It lists the specific capacity, the default numbers of logical cylinders and heads, and the number of logical sectors per track for each product line.

**Table 2-2** Capacity specification

Capacity	Total Bytes	Cylinders	Heads	Sectors	Max LBA
1 GB	992,968,704	1,924	16	63	1,939,392
2 GB	2,002,452,480	3,880	16	63	3,911,040
4 GB	4,021,936,128	7,793	16	63	7,855,344
8 GB	8,061,419,520	15,620	16	63	15,744,960

## 2.2 Environmental Specifications

Environmental specification of the SATA-Disk Chip (SDC) product family which follows the MIL-STD-810F standards is available as shown in Table 2-3.

**Table 2-3:** Environmental specifications

Environment		Specification
Temperature	Operation	-40°C to 85°C
	Storage	-40°C to 100°C
Humidity		5% to 95% RH (Non-condensing)
Vibration (Non-Operation)		Sine wave: 20~2000Hz, 16.3g (X, Y, Z axes)
Shock (Non-Operation)		Half sine wave, Peak acceleration 50 G, 11 ms (X, Y, Z ; All 6 axes)

## 3. Pin Assignments

### 3.1 32 pins (16 x 2)

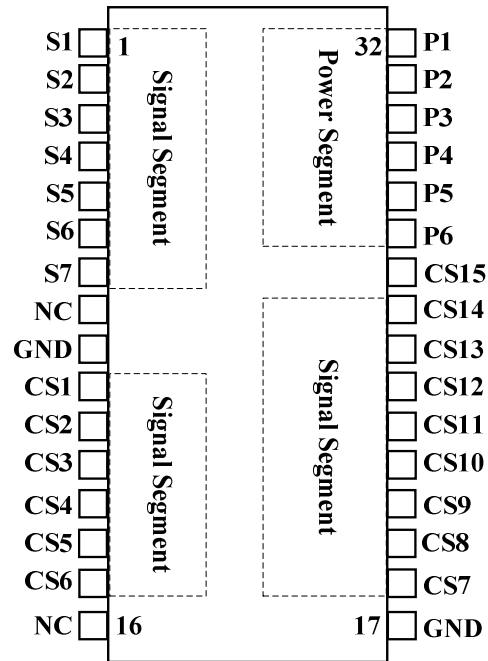

Pin	Name	Type*	Pin	Name	Type*
1	S1	GND	17	GND	GND
2	S2	RX+	18	CS7	Data Act.
3	S3	RX-	19	CS8	RS
4	S4	GND	20	CS9	RS
5	S5	TX-	21	CS10	RS
6	S6	TX+	22	CS11	RS
7	S7	GND	23	CS12	RS
8	NC	-	24	CS13	RS
9	GND	GND	25	CS14	RS
10	CS1	RS1	26	CS15	RS/WP
11	CS2	RS	27	P6	NA/UGND
12	CS3	RS	28	P5	NA/USB+
13	CS4	RS	29	P4	NA/USB-
14	CS5	RS	30	P3	NA/UVCC
15	CS6	PHY RDY	31	P2	GND
16	NC	-	32	P1	VCC3.3

\*RS: Reserved

### 3.2 18 pins (7x2 + 2x2)

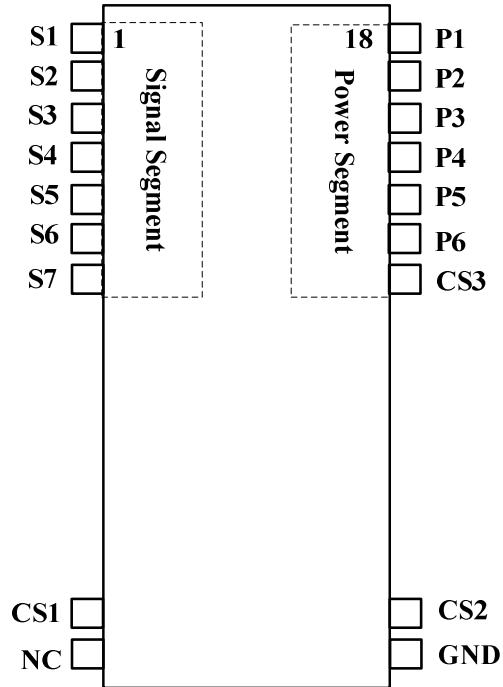

Pin	Name	Type*	Pin	Name	Type*
1	S1	GND	10	GND	GND
2	S2	RX+	11	CS2	Data Act.
3	S3	RX-	12	CS3	RS/WP
4	S4	GND	13	P6	NA/UGND
5	S5	TX-	14	P5	NA/USB+
6	S6	TX+	15	P4	NA/USB-
7	S7	GND	16	P3	NA/UVCC
8	CS1	PHY RDY	17	P2	GND
9	NC	-	18	P1	VCC3.3

\*RS: Reserved

---

## 4. Flash Management

### 4.1 Error Correction/Detection

---

SDC implements a hardware ECC scheme, based on the BCH algorithm. It can detect and correct up to 8 bits or 15 bits error in 512 bytes.

### 4.2 Bad Block Management

---

Although bad blocks on the flash media are already identified by the flash manufacturer, they can also be accumulated over time during operation. SDC's controller maintains a table that lists those normal blocks with disk data, the free blocks for wear leveling, and bad blocks with errors. When a normal block is detected broken, it is replaced with a free block and listed as a bad block. When a free block is detected broken, it is then removed from the free block list and marked as a bad block.

During device operation, this ensures that newly accumulated bad blocks are transparent to the host. The device will stop file write service once there are only two free blocks left such that the read function is still available for copying the files from the disk into another.

### 4.3 Wear Leveling

---

The NAND flash devices are limited by a certain number of write cycles. When using a FAT-based file system, frequent FAT table updates are required. If some area on the flash wears out faster than others, it would significantly reduce the lifetime of the whole SSD, even if the erase counts of others are far from the write cycle limit. Thus, if the write cycles can be distributed evenly across the media, the lifetime of the media can be prolonged significantly. This scheme is called wear leveling.

Apacer's wear-leveling scheme is achieved both via buffer management and Apacer-specific static wear leveling. They both ensure that the lifetime of the flash media can be increased, and the disk access performance is optimized as well.

### 4.4 Power Failure Management

---

The Low Power Detection on the controller initiates crucial data saving before the power supplied to the device is too low. This feature prevents the device from crash and ensures data integrity during an unexpected power-off.

### 4.5 Quick Erase

---

Accomplished by the Secure Erase (SE) command, which added to the open ANSI standards that control disk drives, "Quick Erase" is built into the disk drive itself and thus far less susceptible to malicious software attacks than external software utilities. It is a positive easy-to-use data destroy command, amounting to electronic data shredding. Executing the command causes a drive to internally completely erase all possible user data. This command is carried out within disk drives, so no additional software is required. Once executed, neither data nor the erase counter on the device would be recoverable, which blurs the accuracy of device lifespan. The process to erase will not be stopped until finished while encountering power failure, and will be continued when power is back on.

---

## **4.6 S.M.A.R.T. Technology**

---

S.M.A.R.T. is an acronym for Self-Monitoring, Analysis and Reporting Technology, an open standard allowing disk drives to automatically monitor their own health and report potential problems. It protects the user from unscheduled downtime by monitoring and storing critical drive performance and calibration parameters. Ideally, this should allow taking proactive actions to prevent impending drive failure.

Apacer's SDC uses the standard SMART command B0h to read data from the drive for SMART feature as the SATA Rev.2.6 ATA/ATAPI-7 specifications. Based on the SFF-8035i Rev. 2.0 specifications, Apacer SMART defines 3 vendor-specified SMART Attribute IDs (E5h, EAh-EBh, and E8h) in the SDC. They represent Flash ID, maximum erase count, average erase count, good block count, free-list block count, and firmware version information. When the Apacer SMART Utility running on the host, it analyzes and reports the disk status to the host before the SDC is in critical condition.

## 5. Software Interface

### 5.1 Command Set

This section defines the software requirements and the format of the commands the host sends to the SATA-Disk Chip (SDC). Commands are issued to the SDC by loading the required registers in the command block with the supplied parameters, and then writing the command code to the Command register.

**Table 5-1:** Command set (1 of 2)

Command	Code	FR <sup>1</sup>	SC <sup>2</sup>	SN <sup>3</sup>	CY <sup>4</sup>	DH <sup>5</sup>	LBA <sup>6</sup>
Check-Power-Mode	E5H	-	-	-	-	D <sup>8</sup>	-
Execute-Drive-Diagnostic	90H	-	-	-	-	D	-
Flush-Cache	E7H	-	-	-	-	D	-
Identify-Drive	ECH	-	-	-	-	D	-
Idle	E3H	-	Y	-	-	D	-
Idle-Immediate	E1H	-	-	-	-	D	-
Initialize-Drive-Parameters	91H	-	Y	-	-	Y	-
Read-DMA	C8H or C9H	-	Y	Y	Y	Y	Y
Read-Multiple	C4H	-	Y	Y	Y	Y	Y
Read-Sector(s)	20H or 21H	-	Y	Y	Y	Y	Y
Read-Verify-Sector(s)	40H or 41H	-	Y	Y	Y	Y	Y
Recalibrate	10H	-	-	-	-	D	-
Security-Disable-Password	F6H	-	-	-	-	D	-
Security-Erase-Prepare	F3H	-	-	-	-	D	-
Security-Erase-Unit	F4H	-	-	-	-	D	-
Security-Freeze-Lock	F5H	-	-	-	-	D	-
Security-Set-Password	F1H	-	-	-	-	D	-
Security-Unlock	F2H	-	-	-	-	D	-
Seek	7XH	-	-	-	Y	Y	-
Set-Features	EFH	Y <sup>7</sup>	-	-	-	D	-

**Table 5-1:** Command set (2 of 2)

Command	Code	FR <sup>1</sup>	SC <sup>2</sup>	SN <sup>3</sup>	CY <sup>4</sup>	DH <sup>5</sup>	LBA <sup>6</sup>
Set-Multiple-Mode	C6H	-	Y	-	-	D	-
Sleep	E6H	-	-	-	-	D	-
SMART	B0H	Y	Y	Y	Y	D	
Standby	E2H	-	-	-	-	D	-
Standby-Immediate	E0H	-	-	-	-	D	-
Write-DMA	CAH	-	Y	Y	Y	Y	Y
Write-Multiple	C5H	-	Y	Y	Y	Y	Y
Write-Sector(s)	30H	-	Y	Y	Y	Y	Y

1. FR - Features register
2. SC - Sector Count register
3. SN - Sector Number register
4. CY - Cylinder registers
5. DH - Drive/Head register
6. LBA - Logical Block Address mode supported (see command descriptions for use)
7. Y - The register contains a valid parameter for this command.
8. For the Drive/Head register:  
 Y means both the SDC and Head parameters are used  
 D means only the SDC parameter is valid and not the Head parameter

### 5.1.1 Check Power Mode (E5h)

The host can use this command to determine the current power management mode.

### 5.1.2 Execute Diagnostics (90h)

This command performs the internal diagnostic tests implemented by the drive. See ERROR register for diagnostic codes.

### 5.1.3 Flush Cache (E7h)

This command is used by the host to request the device to flush the write cache. If there is data in the write cache, that data shall be written to the media. The BSY bit shall remain set to one until all data has been successfully written or an error occurs.

### 5.1.4 Identify Device (ECh)

This command read out 512 Bytes of drive parameter information. Parameter information consists of the arrangement and value as shown in the following table. This command enables the host to receive the Identify Drive Information from the device.

**Identify Device Information Default Value (1/9)**

Word	Value	F/V	Description
0	0040h	F	15 0 = ATA device
		X	14-8 Retired
		F	7 1 = removable media device
		X	6 Obsolete
		X	5-3 Retired
		F	2 Reserved
		X	1 Retired
		F	0 Reserved
1	XXXXh	X	Number of logical cylinders
2	C837h	V	Specific configuration
3	00XXh	X	Number of logical heads
4-5	XXXXh	X	Retired
6	XXXXh	X	Number of logical sector per logical track
7-8	XXXXh	V	Reserved for assignment by the Compact Flash Association
9	000Eh	X	Retired
10-19	XXXXh	F	Serial number (20 ASCII characters)
0-21	XXXXh	X	Retired

**SATA-Disk Chip II**  
**AP-SDCxxxxXQANS-ETHT**



**Identify Device Information Default Value (2/9)**

Word	Value	F/V	Description
22	003Fh	X	Obsolete
23-26	XXXXh	F	Firmware revision (8 ASCII characters)
27-46	XXXXh	F	Model number (40 ASCII characters)
47	8000h	F	15-8 80h
		F	7-0 00h = Reserved
		F	01h = Maximum number of 1 sector on READ/WRITE MULTIPLE commands
48	4000h	F	Reserved
49	2F00h		Capabilities
		F	15-14 Reserved for the IDENTIFY PACKET DEVICE command
		F	13 1 = Standby timer values as specified in this standard are supported. 0 = Standby timer values shall be managed by the device.
		F	12 Reserved for the IDENTIFY PACKET DEVICE command
		F	11 1 = IORDY supported 0 = IORDY may be supported
		F	10 1 = IORDY may be disabled
		F	9 1 = LBA supported
		F	8 1 = DMA supported
X	7-0 Retired		
50	4000h		Capabilities
		F	15 Shall be cleared to zero
		F	14 Shall be set to one
		F	13-2 Reserved
		X	1 Obsolete
F	0 Shall be set to one to indicate a device specific Standby timer value minimum		
51	0280h	X	15-8 PIO data transfer cycle timing mode
			7-0 Reserved
52	0000h	X	Obsolete

**Identify Device Information Default Value (3/9)**

Word	Value	F/V	Description
53	0007h	F	15-3 Reserved
		F	2 1 = the fields reported in word 88 are valid 0 = the fields reported in word 88 are not valid
		F	1 1 = the fields reported in word 70:64 are valid 0 = the fields reported in word 70:64 are not valid
		X	0 1 = the fields reported in word 58:54 are valid 0 = the fields reported in word 58:54 are not valid
54	XXXXh	X	Number of current cylinders
55	00XXh	X	Number of current heads
56	XXXXh	X	Number of current sector per track
57-58	XXXXh	X	Current capacity in sectors
59	0000h	F	15-9 Reserved
		V	8 1 = Multiple sector setting is valid
		V	7-0 xxh = Setting for number of sectors that shall be transferred per interrupt on R/W Multiple command
60-61	XXXXh	F	Total number of user addressable sectors
62	0000h	X	Obsolete
63	0007h	F	15-11 Reserved
		V	10 1 = Multiword DMA mode 2 is selected 0 = Multiword DMA mode 2 is not selected
		V	9 1 = Multiword DMA mode 1 is selected 0 = Multiword DMA mode 1 is not selected
		V	8 1 = Multiword DMA mode 0 is selected 0 = Multiword DMA mode 0 is not selected
		F	7-3 Reserved
		F	2 1 = Multiword DMA mode 2 and below are supported
		F	1 1 = Multiword DMA mode 1 and below are supported
		F	0 1 = Multiword DMA mode 0 and below are supported

# SATA-Disk Chip II

## AP-SDCxxxxXQANS-ETHT



### Identify Device Information Default Value (4/9)

Word	Value	F/V	Description
64	0003h	F	15-8 Reserved
		F	7-0 Advanced PIO modes supported
65	0078h	F	Minimum Multiword DMA transfer cycle time per word
66	0078h	F	Manufacturer's recommended Multiword DMA transfer cycle time
67	0078h	F	Minimum PIO transfer cycle time without flow control
68	0078h	F	Minimum PIO transfer cycle time with IORDY flow control
69-79	0000h	F	Reserved (for future command overlap and queuing)
80	01FEh		Major version number 0000h or FFFFh = device does not report version
		F	15 Reserved
		F	14 Reserved for ATA/ATAPI-14
		F	13 Reserved for ATA/ATAPI-13
		F	12 Reserved for ATA/ATAPI-12
		F	11 Reserved for ATA/ATAPI-11
		F	10 Reserved for ATA/ATAPI-10
		F	9 Reserved for ATA/ATAPI-9
		F	8 Reserved for ATA/ATAPI-8
		F	7 1 = supports ATA/ATAPI-7
		F	6 1 = supports ATA/ATAPI-6
		F	5 1 = supports ATA/ATAPI-5
		F	4 1 = supports ATA/ATAPI-4
		F	3 Obsolete
		X	2 Obsolete
X	1 Obsolete		
F	0 Reserved		
81	0021h	F	Minor version number

**Identify Device Information Default Value (5/9)**

Word	Value	F/V	Description	
82	0068h		Command set supported	
		X	15	Obsolete
		F	14	1 = NOP command supported
		F	13	1 = READ BUFFER command supported
		F	12	1 = WRITE BUFFER command supported
		X	11	Obsolete
		F	10	1 = Host Protected Area feature set supported
		F	9	1 = DEVICE RESET command supported
		F	8	1 = SERVICE interrupt supported
		F	7	1 = release interrupt supported
		F	6	1 = look-ahead supported
		F	5	1 = write cache supported
		F	4	Shall be cleared to zero to indicate that the PACKET Command feature set is not supported
		F	3	1 = mandatory Power Management feature set supported
		F	2	1 = Removable Media feature set supported
		F	1	1 = Security Mode feature set supported
F	0	1 = SMART feature set supported		
83	5000h		Command set supported	
		F	15	Shall be cleared to zero
		F	14	Shall be set to one
		F	13-9	Reserved
		F	8	1 = SET MAX security extension supported
		F	7	Reserved
		F	6	1 = SET FEATURES subcommand required to spin-up after power-up
		F	5	1 = Power-Up In Standby feature set supported
		F	4	1 = Removable Media Status Notification feature set supported
		F	3	1 = Advanced Power Management feature set supported
		F	2	1 = CFA feature set supported
		F	1	1 = READ/WRITE DMA QUEUED supported
F	0	1 = DOWNLOAD MICROCODE command supported		

**Identify Device Information Default Value (6/9)**

Word	Value	F/V	Description
84	4000h		Command set/feature supported extension
		F	15      Shall be cleared to zero
		F	14      Shall be set to one
		F	13-2    Reserved
		F	1        1 = SMARAT self-test supported
		F	0        1 = SMARAT error logging supported
85	0008h		Command set/feature enabled
		X	15      Obsolete
		F	14      1 = NOP command enabled
		F	13      1 = READ BUFFER command enabled
		F	12      1 = WRITE BUFFER command enabled
		X	11      Obsolete
		V	10      1 = Host Protected Area feature set enabled
		F	9        1 = DEVICE RESET command enabled
		V	8        1 = SERVICE interrupt enabled
		V	7        1 = release interrupt enabled
		V	6        1 = look-ahead enabled
		V	5        1 = write cache enabled
		F	4        Shall be cleared to zero to indicate that the PACKET Command feature set is not supported
		F	3        1 = mandatory Power Management feature set enabled
F	2        1 = Removable Media feature set enabled		
V	1        1 = Security Mode feature set enabled		
V	0        1 = SMART feature set enabled		

**Identify Device Information Default Value (7/9)**

Word	Value	F/V	Description
86	5000h		Command set/feature enabled
		F	15-9      Reserved
		F	8            1 = SET MAX security extension enabled by SET MAX SET PASSWORD
		F	7            See Address Offset Reserved Area Boot, INCITS TR27:2001
		F	6            1 = SET FEATURES subcommand required to spin-up after power-up
		F	5            1 = Power-Up In Standby feature set enabled
		F	4            1 = Removable Media Status Notification feature set enabled
		F	3-1         1 = Advanced Power Management feature set enabled
		F	0            1 = DOWNLOAD MICROCODE command supported
87	4000h		Command set/feature default
		F	15          Shall be cleared to zero
		F	14          Shall be set to one
		F	13-2        Reserved
		F	1            1 = SMARAT self-test supported
		F	0            1 = SMARAT error logging supported

**Identify Device Information Default Value (8/9)**

Word	Value	F/V	Description
88	203Fh	V	15-13 Reserved 12 1 = Ultra DMA mode 4 is selected 0 = Ultra DMA mode 4 is not selected
		V	11 1 = Ultra DMA mode 3 is selected 0 = Ultra DMA mode 3 is not selected
		V	10 1 = Ultra DMA mode 2 is selected 0 = Ultra DMA mode 2 is not selected
		V	9 1 = Ultra DMA mode 1 is selected 0 = Ultra DMA mode 1 is not selected
		V	8 1 = Ultra DMA mode 0 is selected 0 = Ultra DMA mode 0 is not selected
		F	7-5 Reserved
		F	4 1 = Ultra DMA mode 4 and below are supported
		F	3 1 = Ultra DMA mode 3 and below are supported
		F	2 1 = Ultra DMA mode 2 and below are supported
		F	1 1 = Ultra DMA mode 1 and below are supported
		F	0 1 = Ultra DMA mode 0 and below are supported
		89	0000h
90	0000h	F	Time required for Enhanced security erase completion
91	0000h	V	Current advanced power management value
92	0000h	V	Master Password Revision Code
93	0000h	X	Hardware reset result
94-126	0000h	V	Reserved
127	0000h	F	Removable Media Status Notification feature set support 15-2 Reserved
		F	1-0 00 = Removable Media Status Notification feature set not supported 01 = Removable Media Status Notification feature set supported 10 = Reserved 11 = Reserved

**Identify Device Information Default Value (9/9)**

Word	Value	F/V	Description
128	0001h		Security status
		F	15-9      Reserved
		V	8          Security level 0 = High, 1 = Maximum
		F	7-6      Reserved
		F	5          1 = Enhanced security erase supported
		V	4          1 = Security count expired
		V	3          1 = Security frozen
		V	2          1 = Security locked
		V	1          1 = Security enabled
F	0          1 = Security supported		
129-159	0000h	X	Vendor specific
160-254	0000h	X	Reserved
255	0000h	X	Integrity word
			15-8      Checksum
			7-0      Signature
<p>Key:</p> <p>F/V = Fixed/variable content</p> <p>F = the content of word is fixed and does not change. For removable media devices, these values may change when media is removed or changed.</p> <p>V = the contents of the word is variable and may change depending on the state of the device or the commands executed by the device.</p> <p>X = the content of the word may be fixed or variable.</p>			

### 5.1.5 Idle (E3h)

This command causes the device to set BSY, enter the Idle mode, clear BSY and generate an interrupt. If sector count is non-zero, the automatic power down mode is enabled. If the sector count is zero, the automatic power mode is disabled.

### 5.1.6 Idle Immediate (E1h)

This command causes the device to set BSY, enter the Idle(Read) mode, clear BSY and generate an interrupt.

### 5.1.7 Initialize Drive Parameters (C8h)

This command enables the host to set the number of sectors per track and the number of tracks per heads.

### **5.1.8 Read DMA (C8h)**

Read data from sectors during Ultra DMA and Multiword DMA transfer. Use the SET FEATURES command to specify the mode value. A sector count of zero requests 256 sectors.

### **5.1.9 Read Multiple (C4h)**

This command performs similarity to the Read Sectors command. Interrupts are not generated on each sector, but on the transfer of a block which contains the number of sectors defined by a Set Multiple command.

### **5.1.10 Read Sector(s) (20h)**

This command reads 1 to 256 sectors as specified in the Sector Count register from sectors which is set by Sector number register. A sector count of zero requests 256 sectors. The transfer beings specified in the Sector Number register.

### **5.1.11 Read Verify Sector(s) (40h)**

This command verifies one or more sectors on the drive by transferring data from the flash media to the data buffer in the drive and verifying that the ECC is correct. This command is identical to the Read Sectors command, except the DRQ is never set and no data is transferred to the host.

### **5.1.12 Recalibrate (10h)**

The current drive performs no processing if it receives this command. It is supported for backward compatibility with previous devices.

### **5.1.13 Security Disable Password (F6h)**

Disables any previously set user password and cancels the lock. The host transfers 512 bytes of data, as shown in the following table, to the drive. The transferred data contains a user or master password, which the drive compares with the saved password. If they match, the drive cancels the lock. The master password is still saved. It is re-enabled by issuing the SECURITY SET PASSWORD command to reset a user password.

### **5.1.14 Security Erase Prepare (F3h)**

This command shall be issued immediately before the Security Erase Unit command to enable erasing and unlocking. This command prevents accidental loss of data on the drive.

### **5.1.15 Security Erase Unit (F4h)**

The host uses this command to transfer 512 bytes of data, as shown in the following table, to the drive. The transferred data contains a user or master password, which the drive compares with the saved password. If they match, the drive deletes user data, disables the user password, and cancels the locks. The master password is still saved. It is re-enabled by issuing the SECURITY SET PASSWORD command to reset a user password.

### 5.1.16 Security Freeze Lock (F5h)

Causes the drive to enter Frozen mode. Once this command has been executed, the following commands to update a lock result in the Aborted Command error:

- SECURITY SET PASSWORD
- SECURITY UNLOCK
- SECURITY DISABLE PASSWORD
- SECURITY ERASE PREPARE
- SECURITY ERASE UNIT

The drive exits from Frozen mode upon a power-off or hard reset. If the SECURITY FREEZE LOCK command is issued when the drive is placed in Frozen mode, the drive executes the command, staying the Frozen mode.

### 5.1.17 Security Set Password (F1h)

This command sets user password or master password. The host outputs sector data with PIO data-out protocol to indicate the information defined in the following table.

### 5.1.18 Security Unlock (F2h)

This command disables LOCKED MODE of the device. This command transfers 512 byte of data from the host with PIO data-out protocol. The following table defines the content of this information.

### 5.1.19 Seek (7xh)

This command is effectively a NOP command to the device although it does perform a range check.

### 5.1.20 Set Features (EFh)

This command set parameter to Features register and set drive's operation. For transfer mode, parameter is set to Sector Count register. This command is used by the host to establish or select certain features.

**Features register Value and settable operating mode**

Value	Function
02h	Enable write cache
03h	Set transfer mode based on value in Sector Count register.
55h	Disable read look-ahead feature
82h	Disable write cache
AAh	Enable read look-ahead feature

### 5.1.21 Set Multiple Mode (C6h)

This command enables the device to perform READ MULTIPLE and WRITE MULTIPLE operations and establishes the block count for these commands.

### 5.1.22 Sleep (E6h)

This command causes the device to set BSY, enter the Sleep mode, clear BSY and generate an interrupt.

### 5.1.23 SMART (B0h)

Performs different processing required for predicting device failures, according to the subcommand specified in the Features register. If the Features register contains an unsupported value, the Aborted Command error is returned. If the SMART function is disabled, any subcommand other than SMART ENABLE OPERATIONS results in the Aborted Command error.

Code	Smart Subcommand
D0h	READ DATA
D1h	READ ATTRIBUTE THRESHOLDS
D2h	ENABLE/DISABLE ATTRIBUTE AUTOSAVE
D3h	SAVE ATTRIBUTE VALUES
D4h	EXECUTE OFF-LINE IMMEDIATE*
D5h	Reserved
D6h	Reserved
D8h	ENABLE OPERATIONS
D9h	DISABLE OPERATIONS
DAh	RETURN STATUS
DBh	ENABLE/DISABLE AUTO OFF-LINE*

### SMART READ DATA

This command returns 512-byte SMART Data Structure to the host with PIO data-in protocol. The register file has to contain D0h for Features register, 4Fh for LBA Mid register and C2h for the LBA High register.

Byte	Description
0-1	Data structure revision number
2-13	1 <sup>st</sup> attribute data
14-361	2 <sup>nd</sup> -30 <sup>th</sup> Individual attribute data
362	Off-line data collection status
363	Reserved
364-365	Total time in seconds to complete off-line data collection
366	Reserved
367	Off-line data collection capability
368-369	SMART capability
370-385	Reserved
386-510	Reserved
511	Data structure checksum

#### Byte 2-361: Individual attribute data

Byte	Description
0	Attribute ID
1-2	Status Flag (0x0002)
3	Attribute Value (0x64)
4-11	Vendor Specific

The attribute ID information is listed in the following table

ID	Description	Detail Information	
		Byte	Description
E5h	Halt System ID, Flash ID	0	Halt System ID
		1	Flash ID (byte 1)
		2	Flash ID (byte 2)
		3	Flash ID (byte 3)
		4	Flash ID (byte 4)
		5	Flash ID (byte 5)
		6	Flash ID (byte 6)
		7	Flash ID (byte 7)
E8h	Firmware version information	0	Year (High Byte, ASCII)
		1	Year (Low Byte, ASCII)
		2	Month (High Byte, ASCII)
		3	Month (Low Byte, ASCII)
		4	Day (High Byte, ASCII)
		5	Day (Low Byte, ASCII)
		6	Channels (binary)
		7	Banks (binary)
E9h	ECC Fail Record	0	ECC fail number
		1	Row address 3
		2	Row address 2
		3	Row address 1
		4	Channel number of last ECC fail
		5	Bank number of last ECC fail
		6	Reserved
		7	Reserved
EAh	Average Erase Count, Max Erase Count	0	Average Erase Count (High Byte)
		1	Average Erase Count
		2	Average Erase Count (Low Byte)
		3	Max Erase Count (High Byte)
		4	Max Erase Count
		5	Max Erase Count (Low Byte)
		6	Reserved
		7	Reserved
EBh	Good Block Count, System Block Count	0	Good Block Count (High Byte)
		1	Good Block Count
		2	Good Block Count (Low Byte)
		3	System(Free) Block Count (High Byte)
		4	System(Free) Block Count Count
		5	System(Free) Block Count Count (Low Byte)
		6	Reserved
		7	Reserved
ECh-FFh	Reserved		

### SMART READ ATTRIBUTE THRESHOLD

This transfers 512 bytes of drive failure threshold data to the host.

### SMART ENABLE/DISABLE ATTRIBUTE AUTOSAVE

Enables or disables the attribute value autosave function. This command specifies whether the current attribute values are automatically saved to the drive when it changes the mode. This setting is maintained when the power is turned on and off.

### SMART SAVE ATTRIBUTE VALUE

Saves any modified attribute values.

### **SMART ENABLE OPERATIONS**

Enables the SMART function. This setting is maintained when the power is turned off and then back on. Once the SMART function is enabled, subsequent SMART ENABLE OPERATIONS commands do not affect any parameter.

### **SMART DISABLE OPERATIONS**

Disables the SMART function. Upon receiving the command, the drive disables all SMART operations. This setting is maintained when the power is turned off and then back on.

Once this command has been received, all SMART commands other than SMART ENABLE OPERATIONS are aborted with the Aborted Command error.

This command disables all SMART capabilities including any and all timer and event count functions related exclusively to this feature. After command acceptance, this controller will disable all SMART operations. SMART data is no longer be monitored or saved. The state of SMART is preserved across power cycles.

### **SMART RETURN STATUS**

Reports the drive reliability status.

Values reported when a predicted defect has not been detected:

Cylinder Low register: 4Fh

Cylinder High register: C2h

Values reported when a predicted defect has been detected:

Cylinder Low register: F4h

Cylinder High register: 2Ch

### **SMART ENABLE/DISABLE AUTOMATIC OFF-LINE**

Enables (when Sector Count register = "F8h") or disables (Sector Count register = "00h") the automatic off-line data collection function.

The automatic collection is disabled if a value of "00h" is set in the Sector Count register before a subcommand is issued. If automatic collection is disabled, the drive can still save attribute information during normal operation, such as during the power-on/off sequence or error correction sequence.

The automatic collection function is enabled if a value of "F8h" is set in the Sector Count register before the command is issued. Values other than "00h" and "F8h" are vendor-specific.

#### **5.1.24 Standby (E2h)**

This command causes the device to set BSY, enter the Sleep mode (which corresponds to the ATA "Standby" Mode), clear BSY and return the interrupt immediately.

#### **5.1.25 Standby Immediate (E0h)**

This command causes the device to set BSY, enter the Sleep mode (which corresponds to the ATA "Standby" Mode), clear BSY and return the interrupt immediately.

---

### **5.1.26 Write DMA (CAh)**

Write data to sectors during Ultra DMA and Multiword DMA transfer. Use the SET FEATURES command to specify the mode value.

### **5.1.27 Write Multiple (C5h)**

This command is similar to the Write Sectors command. Interrupts are not presented on each sector, but on the transfer of a block which contains the number of sectors defined by Set Multiple command.

### **5.1.28 Write Sector(s) (30h)**

Write data to a specified number of sectors (1 to 256, as specified with the Sector Counter register) from the specified address. Specify "00h" to write 256 sectors.

## 6. Physical Characteristics

### 6.1 Dimension of 32 pins (16x2)

TOP VIEW

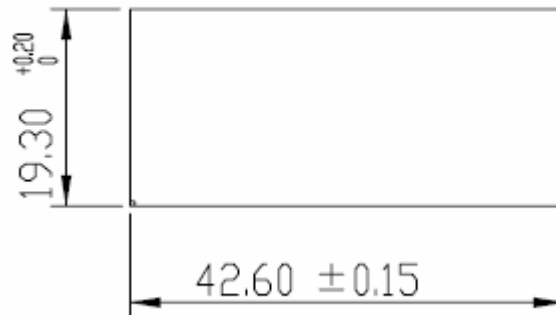

BOTTOM VIEW

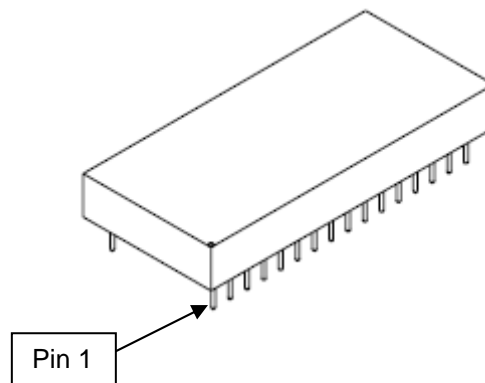
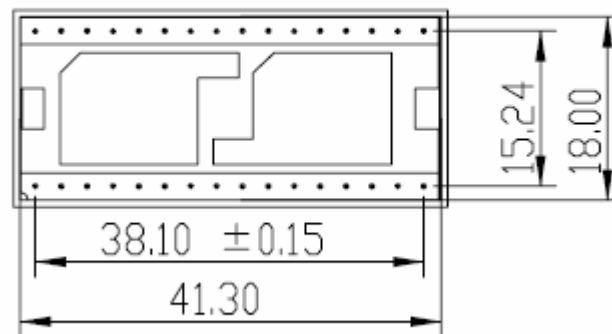

Unit: mm  
Tolerance:  $\pm 0.25$

SATA-Disk Chip II  
AP-SDCxxxxXQANS-ETHT

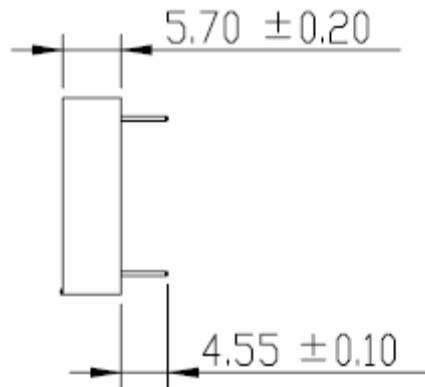
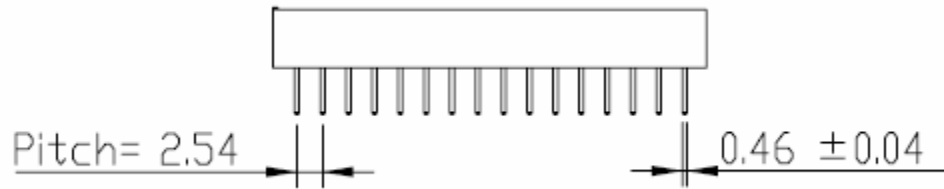

Unit: mm  
Tolerance:  $\pm 0.25$

## 6.2 Dimension of 18 pins (7x2 + 2x2)

TOP VIEW

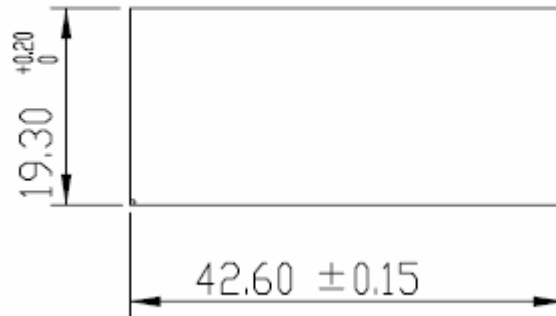

BOTTOM VIEW

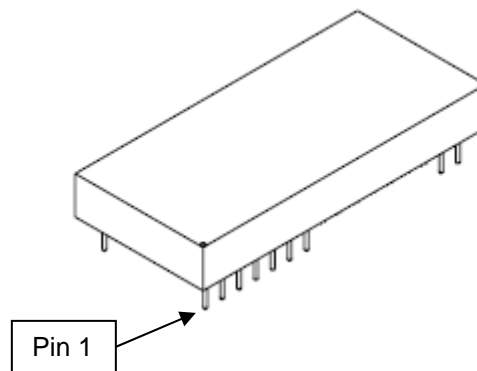
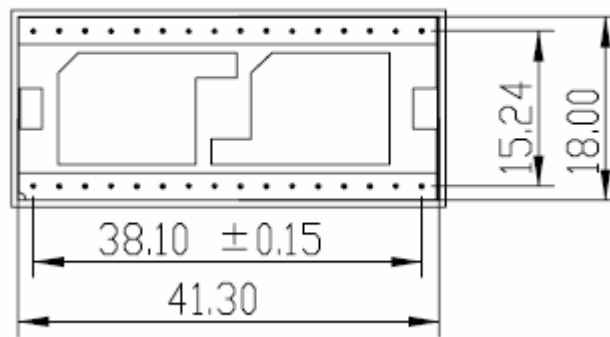

Unit: mm  
Tolerance: ± 0.25

SATA-Disk Chip II  
AP-SDCxxxxXQANS-ETHT

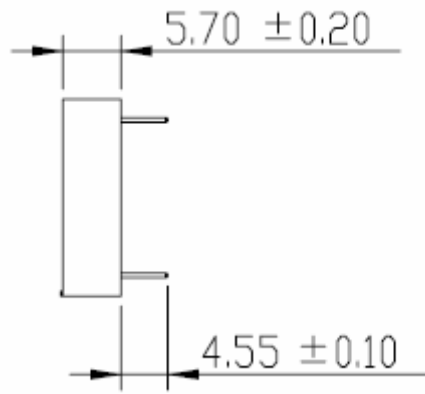
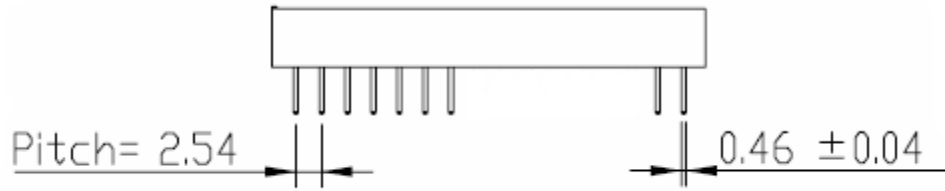

Unit: mm  
Tolerance:  $\pm 0.25$

## 7. Product Ordering Information

### 7.1 Product Code Designations

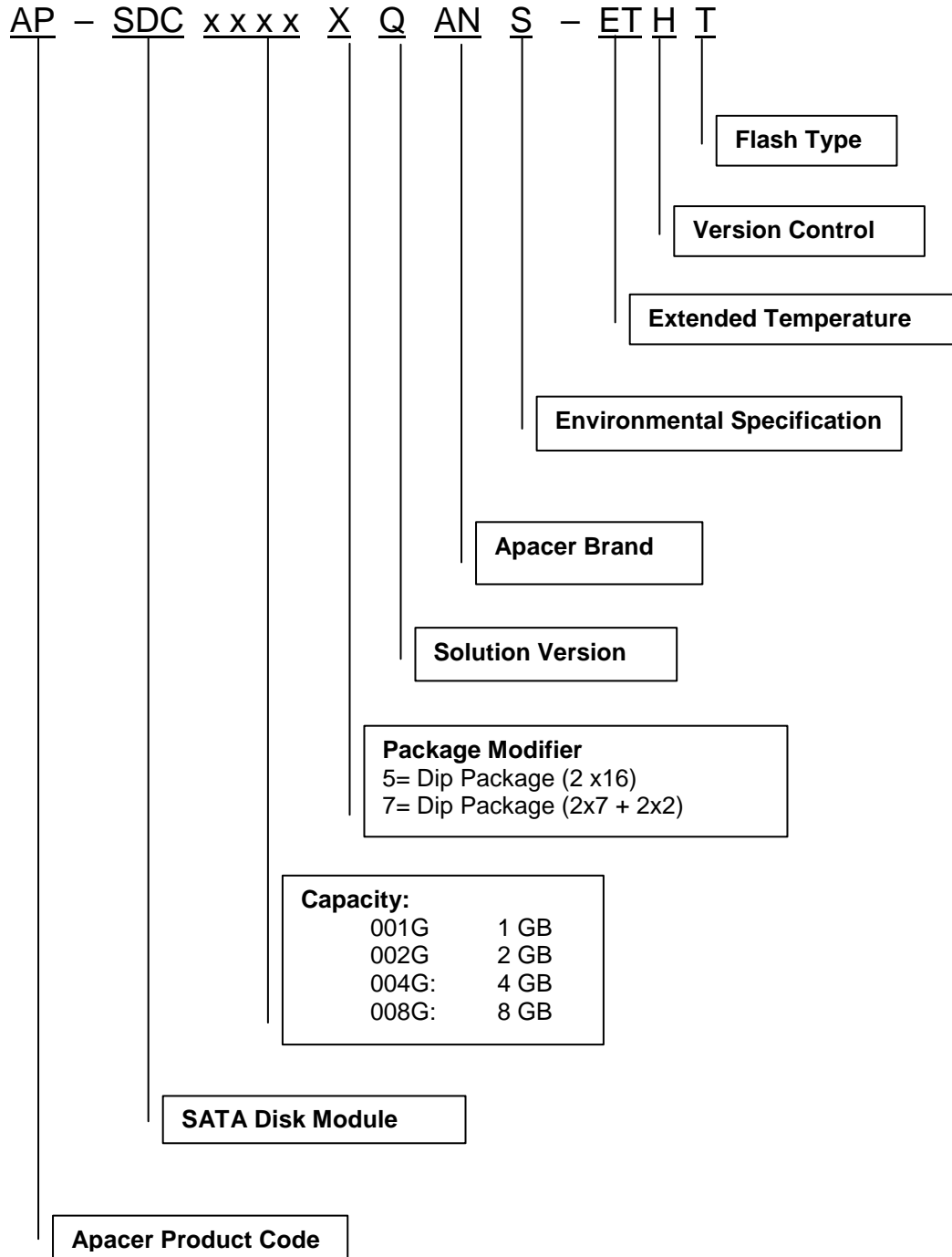

---

## 7.2 Valid Combinations

---

### SDCII 2 x 16 pin

Capacity	Model Number
1GB	AP-SDC001G5QDNS-ETHT
2GB	AP-SDC002G5QDNS-ETHT
4GB	AP-SDC004G5QDNS-ETHT
8GB	AP-SDC008G5QDNS-ETHT

### SDCII (2x7 + 2x2) pin

Capacity	Model Number
1GB	AP-SDC001G7QDNS-ETHT
2GB	AP-SDC002G7QDNS-ETHT
4GB	AP-SDC004G7QDNS-ETHT
8GB	AP-SDC008G7QDNS-ETHT

**Note:** Valid combinations are those products in mass production or will be in mass production. Consult your Apacer sales representative to confirm availability of valid combinations and to determine availability of new combinations.

---

## Revision History

Revision	Date	Description	Remark
1.0	08/04/2009	Official release	
1.1	08/18/2009	Updated performance	
1.2	11/18/2009	Supplemented capacity specification details	
1.3	01/18/2011	Updated product ordering information	

## Global Presence

<b>Taiwan (Headquarters)</b>	<b>Apacer Technology Inc.</b> 4 <sup>th</sup> Fl., 75 Xintai 5 <sup>th</sup> Rd., Sec.1 Hsichih, New Taipei City Taiwan 221 R.O.C. Tel: +886-2-2698-2888 Fax: +886-2-2698-2889 <a href="mailto:amtsales@apacer.com">amtsales@apacer.com</a>
<b>U.S.A.</b>	<b>Apacer Memory America, Inc.</b> 386 Fairview Way, Suite102, Milpitas, CA 95035 Tel: 1-408-518-8699 Fax: 1-408-935-9611 <a href="mailto:sa@apacerus.com">sa@apacerus.com</a>
<b>Japan</b>	<b>Apacer Technology Corp.</b> 5F, Matsura Bldg., Shiba, Minato-Ku Tokyo, 105-0014, Japan Tel: 81-3-5419-2668 Fax: 81-3-5419-0018 <a href="mailto:jpservices@apacer.com">jpservices@apacer.com</a>
<b>Europe</b>	<b>Apacer Technology B.V.</b> Aziëlaan 22, 5232 BA 's-Hertogenbosch, The Netherlands Tel: 31-73-645-9620 Fax: 31-73-645-9629 <a href="mailto:sales@apacer.nl">sales@apacer.nl</a>
<b>China</b>	<b>Apacer Electronic (Shanghai) Co., Ltd</b> 1301, No.251,Xiaomuqiao Road, Shanghai, 200032, China Tel: 86-21-5529-0222 Fax: 86-21-5206-6939 <a href="mailto:sales@apacer.com.cn">sales@apacer.com.cn</a>
<b>India</b>	<b>Apacer Technologies Pvt Ltd,</b> #1064, 1st Floor, 7th 'A' Main, 3rd Block Koramangala, Bangalore – 560 034 Tel: +91 80 4152 9061/62/63 Fax: +91 80 4170 0215 <a href="mailto:sales_india@apacer.com">sales_india@apacer.com</a>