



**eBOX530-820-FL Series  
Embedded System  
User's Manual**



## **Disclaimers**

This manual has been carefully checked and believed to contain accurate information. AXIOMTEK Co., Ltd. assumes no responsibility for any infringements of patents or any third party's rights, and any liability arising from such use.

AXIOMTEK does not warrant or assume any legal liability or responsibility for the accuracy, completeness or usefulness of any information in this document. AXIOMTEK does not make any commitment to update the information in this manual.

AXIOMTEK reserves the right to change or revise this document and/or product at any time without notice.

No part of this document may be reproduced, stored in a retrieval system, or transmitted, in any form or by any means, electronic, mechanical, photocopying, recording, or otherwise, without the prior written permission of AXIOMTEK Co., Ltd.

**©Copyright 2009 AXIOMTEK Co., Ltd.  
All Rights Reserved  
November 2009, Version A3  
Printed in Taiwan**

## Safety Precautions

Before getting started, please read the following important safety precautions.

1. The **eBOX530-820-FL** does not come equipped with an operating system. An operating system must be loaded first before installing any software into the computer.
2. Be sure to ground yourself to prevent static charge when installing the internal components. Use a grounding wrist strap and place all electronic components in any static-shielded devices. Most electronic components are sensitive to static electrical charge.
3. Disconnect the power cord from the **eBOX530-820-FL** before making any installation. Be sure both the system and the external devices are turned OFF. Sudden surge of power could ruin sensitive components. Make sure the **eBOX530-820-FL** is properly grounded.
4. Make sure the voltage of the power source is correct before connecting the equipment to the power outlet.
5. Turn OFF the system power before cleaning. Clean the system using a cloth only. Do not spray any liquid cleaner directly onto the screen.
6. Do not leave this equipment in an uncontrolled environment where the storage temperature is below -20 or above 60 . It may damage the equipment.
7. Do not open the system's back cover. If opening the cover for maintenance is a must, only a trained technician is allowed to do so. Integrated circuits on computer boards are sensitive to static electricity. To avoid damaging chips from electrostatic discharge, observe the following precautions:
  - Before handling a board or integrated circuit, touch an unpainted portion of the system unit chassis for a few seconds. This will help to discharge any static electricity on your body.
  - When handling boards and components, wear a wrist-grounding strap, available from most electronic component stores.

## Classification

1. Degree of protection against electric shock: not classified
2. Degree of protection against the ingress of water: IPX0
3. Equipment not suitable for use in the presence of a flammable anesthetic mixture with air or with oxygen or nitrous oxide.
4. Mode of operation: Continuous
5. Type of protection against electric shock: Class I equipment

## General Cleaning Tips

You may need the following precautions before you begin to clean the computer. When you clean any single part or component for the computer, please read and understand the details below fully.

When you need to clean the device, please rub it with a piece of dry cloth.

1. Be cautious of the tiny removable components when you use a vacuum cleaner to absorb the dirt on the floor.
2. Turn the system off before you start to clean up the component or computer.
3. Never drop the components inside the computer or get circuit board damp or wet.
4. Be cautious of all kinds of cleaning solvents or chemicals when you use it for the sake of cleaning. Some individuals may be allergic to the ingredients.
5. Try not to put any food, drink or cigarette around the computer.

### Cleaning Tools:

Although many companies have created products to help improve the process of cleaning your computer and peripherals users can also use household items to clean their computers and peripherals. Below is a listing of items you may need or want to use while cleaning your computer or computer peripherals.

Keep in mind that some components in your computer may only be able to be cleaned using a product designed for cleaning that component, if this is the case it will be mentioned in the cleaning.

- Cloth: A piece of cloth is the best tool to use when rubbing up

a component. Although paper towels or tissues can be used on most hardware as well, we still recommend you to rub it with a piece of cloth.

- Water or rubbing alcohol: You may moisten a piece of cloth a bit with some water or rubbing alcohol and rub it on the computer. Unknown solvents may be harmful to the plastics parts.
- Vacuum cleaner: Absorb the dust, dirt, hair, cigarette particles, and other particles out of a computer can be one of the best methods of cleaning a computer. Over time these items can restrict the airflow in a computer and cause circuitry to corrode.
- Cotton swabs: Cotton swabs moistened with rubbing alcohol or water are excellent tools for wiping hard to reach areas in your keyboard, mouse, and other locations.
- Foam swabs: Whenever possible it is better to use lint free swabs such as foam swabs.



**Note** *We strongly recommended that you should shut down the system before you start to clean any single components.*

**Please follow the steps below:**

1. Close all application programs
2. Close operating software
3. Turn off power switch
4. Remove all device
5. Pull out power cable

## **Scrap Computer Recycling**

If the computer equipments need the maintenance or are beyond repair, we strongly recommended that you should inform your AXIOMTEK distributor as soon as possible for the suitable solution. For the computers that are no longer useful or no longer working well, please contact your AXIOMTEK distributor for recycling and we will make the proper arrangement.

## **Trademarks Acknowledgments**

AXIOMTEK is a trademark of AXIOMTEK Co., Ltd.

IBM, PC/AT, PS/2, VGA are trademarks of International Business Machines Corporation.

Intel<sup>®</sup> and Pentium<sup>®</sup> are registered trademarks of Intel Corporation.

MS-DOS, Microsoft C and QuickBASIC are trademarks of Microsoft Corporation.

VIA is a trademark of VIA Technologies, Inc.

SST is a trademark of Silicon Storage Technology, Inc.

UMC is a trademark of United Microelectronics Corporation.

Other brand names and trademarks are the properties and registered brands of their respective owners.

# Table of Contents

<b>Disclaimers</b> .....	ii
<b>Safety Precautions</b> .....	iii
<b>Classification</b> .....	iv
<b>General Cleaning Tips</b> .....	iv
<b>Scrap Computer Recycling</b> .....	vi
<b>CHAPTER 1 INTRODUCTION</b> .....	<b>1</b>
1.1 General Description .....	1
1.2 System Specifications .....	3
1.2.1 CPU .....	3
1.2.2 I/O System .....	3
1.2.3 System Specification .....	3
1.3 Dimensions .....	5
1.4 I/O Outlets .....	6
1.5 Packing List .....	8
<b>CHAPTER 2 HARDWARE INSTALLATION</b> .....	<b>10</b>
2.1 Installing the Memory Module .....	10
2.2 Installing the Hard Disk Drive .....	14
2.3 Installing the CompactFlash™ Card .....	18
2.4 Installing DIN Mount (optional) .....	22
2.5 Installing Rail Mount .....	24
<b>CHAPTER 3 PHOENIX-AWARD BIOS UTILITY</b> .....	<b>26</b>
3.1 Entering Setup .....	26
3.2 Control Keys .....	27
3.3 Getting Help .....	27
3.4 The Main Menu .....	28
3.5 Standard CMOS Setup Menu .....	29
3.6 Advanced BIOS Features .....	31
3.7 Advanced Chipset Features .....	34
3.8 Integrated Peripherals .....	36
3.9 Power Management Setup .....	39
3.10 PnP/PCI Configuration Setup .....	42
3.11 PC Health Status .....	44
3.12 Frequency/Voltage Control .....	45
3.13 Load Optimized Defaults .....	46
3.14 Set Supervisor/User Password .....	47
3.15 Save & Exit Setup .....	48
3.16 Exit Without Saving .....	49
<b>CHAPTER 4 INSTALLATION OF DRIVERS</b> .....	<b>50</b>
4.1 Installing Chipset Driver .....	50
4.2 Installing VGA Driver .....	53
4.3 Installing LAN Driver .....	57
4.4 Installing Audio Driver .....	59

***MEMO***

# CHAPTER 1

## INTRODUCTION

This chapter contains general information and detailed specifications of the **eBOX530-820-FL**. The Chapter 1 includes the following sections:

- **General Description**
- **System Specification**
- **Dimensions**
- **I/O Outlets**
- **Package List**

### 1.1 General Description

The **eBOX530-820-FL** is an embedded system that supports onboard Intel® ATOM™ Z510 (1.1 GHz) or Z530 (1.6 GHz) processors to provide Windows® XPE, Windows® XP, Windows® WinCE embedded and Linux, suitable for the most endurable operation. It features fanless design with full feature I/O, one 200-pin DDR2 SODIMM maximum up to 2GB, and enhanced system dependability by built-in Watchdog Timer.

➤ **Features**

1. Support Intel® ATOM™ processors up to 1.6 GHz
2. Intel® US15W core logic chipset
3. Ultra slim and compact design
4. Supports 4 USB 2.0 ports and 2 COM ports
5. Supports one 10/100/1000Mbps Ethernet port
6. One 2.5" SATA HDD drive bay, one CompactFlash™
7. Watchdog timer
8. Din-rail/desktop/wall mount

➤ **Reliable and Stable Design**







The **eBOX530-820-FL** adopts the advanced cooling system and supporting the CompactFlash™, which makes it especially suitable for vibration environments, best for industrial automation, digital signage and gaming application.

➤ **Embedded O.S. Supported**

The **eBOX530-820-FL** not only supports Windows® XP, but also supports embedded OS, such as Windows® XP embedded, WinCE and Linux. For storage device, the **eBOX530-820-FL** supports one 2.5" SATA HDD drive bay, and one type II CompactFlash™ slot.

➤ **ATX or AT Mode Selection Jumper (JP3)**

ATX Mode or AT Mode via the jumper changed. We are herewith listing as below.

Description/ Function	Jumper Setting
<p><u>AUTO BUTTON</u> Mode Selection (<b>AT Mode</b>) Function : <u>ON</u></p>	<p>1  2  3  Short 1-2</p>
<p><u>AUTO BUTTON</u> Mode Selection (<b>ATX Mode</b>) Function : <u>OFF</u></p>	<p>1  2  3  Short 2-3</p>



**NOTE**

Once the Jumper is changed to AT model, the system power switch is no longer usable and system will power-on once DC power enter system. Therefore, customer needs to have external power switch to switch on/off the system (because eBOX530's power switch is no longer workable at AT mode).

## 1.2 System Specifications

### 1.2.1 CPU

- **CPU**
  - Onboard Intel<sup>®</sup> ATOM<sup>™</sup> Z510 (1.1 GHz) or Z530 (1.6 GHz) processors
- **BIOS**
  - Phoenix-Award BIOS, 4Mbit with RPL/PXE LAN Boot ROM, SmartView and Customer CMOS Backup
- **System Memory**
  - One 200-pin DDR2 400/533MHz SODIMM max. up to 2 GB

### 1.2.2 I/O System

- **System I/O Outlet**
  - Two 9-pin D-Sub male connectors, COM1/2 for RS-232
  - One 15-pin D-Sub female connector for VGA
  - One Audio connector (Line-IN, Line-OUT)
  - One PS/2 connector for Keyboard and M/S through Y-Type cable
  - One RJ-45 connector for 10/100/1000Base-T Ethernet
  - Four USB 2.0 connectors
  - One 5V DC-IN Power Input connector

### 1.2.3 System Specification

- **Watchdog Timer**
  - Reset supported; 255 levels, 0~255 sec.
- **Power Supply**
  - External 5V AC/DC power adapter
- **Operation Temperature**
  - 0 ~ 50 (32 °F ~ 122°F), with W.T. HDD
- **Storage Temperature**

- -20 ~ 80 (-4 °F ~ 176°F)
- **Humidity**
  - 10% ~ 90% (non-condensation)
- **Vibration Endurance**
  - 1Grms w/ HDD (5 ~ 500Hz, X, Y, Z directions)
- **Weight**
  - 0.5 kg (1.1 lb)
- **Dimensions**
  - 130mm(5.11") (W) x 95.4mm(3.75") (D) x 47.1mm(1.85") (H)



**NOTE** *All specifications and images are subject to change without notice.*

### 1.3 Dimensions

The following diagrams show you dimensions and outlines of the eBOX530-820-FL.

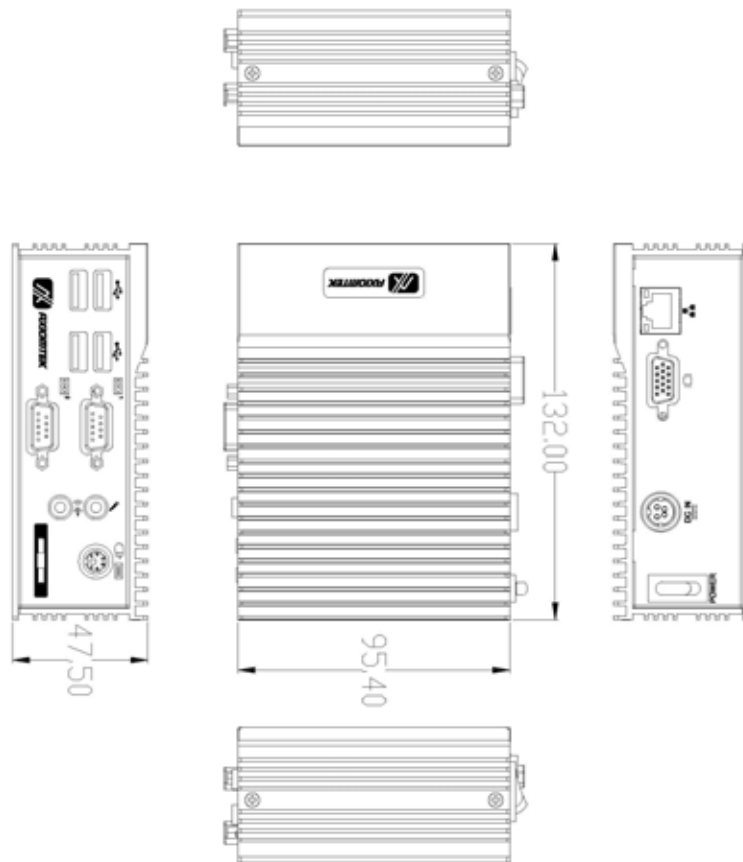

## 1.4 I/O Outlets

The following figures show you I/O outlets on front view of the eBOX530-820-FL.

- **Front View**

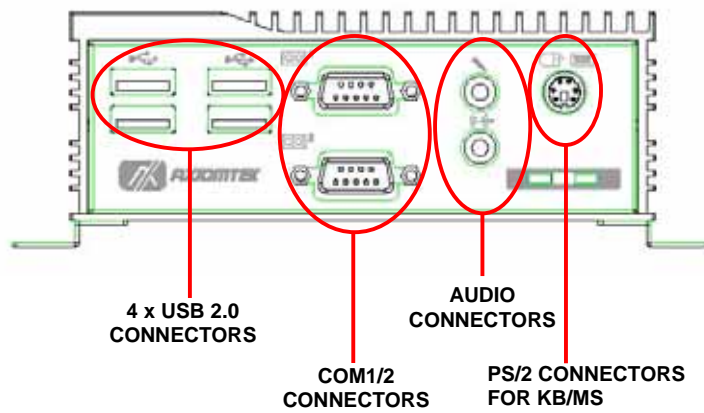

- **Rear View**

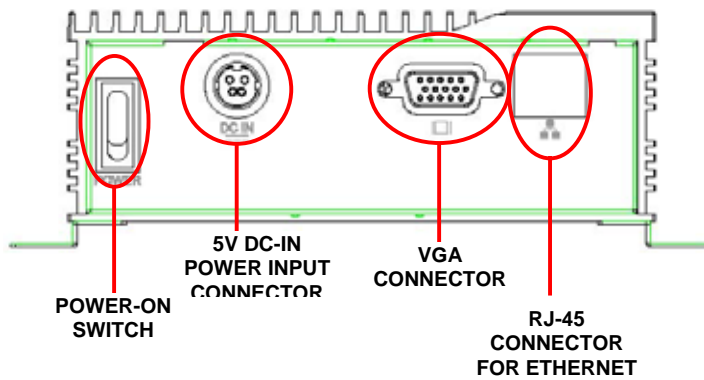

- **SATA Connector**

The SATA connector is for high-speed SATA interface ports and each SATA connector supports a single SATA device.

Pin	Signal
1	GND
2	SATA_TX+
3	SATA_TX-
4	GND
5	SATA_RX-
6	SATA_RX+
7	GND

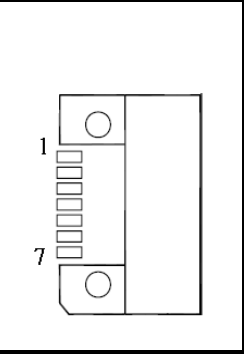

The diagram shows a side view of a SATA connector with 7 pins. Pin 1 is at the top, and pin 7 is at the bottom. The pins are arranged in a 1-2-3-4-5-6-7 sequence from top to bottom.

Plug one end of the SATA cable to the SATA connector, and the other end of cable to the SATA hard drive.

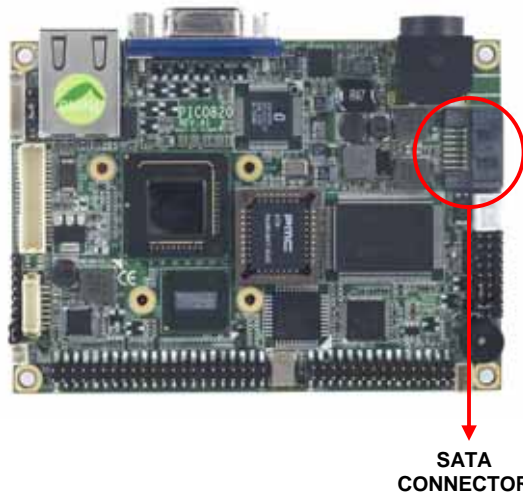

## 1.5 Packing List

The package bundled with your **eBOX530-820-FL** should contain the following items:

- eBOX530-820-FL System Unit x 1
- eBOX530-820-FL Quick Manual x 1
- Notice x1
- Power Cord x 1
- CD x 1 (For Driver and User's Manual)
- Wallmount Brackets
- Keyboard/Mouse Y-cable
- Screws
- 25W 5V AC/DC Power Adapter
- HDD Mylar x1

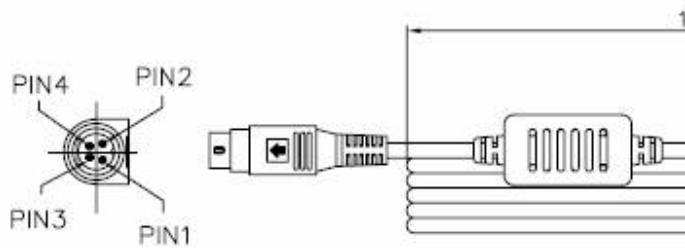

DIN PLUG	POLARITY	COLOR
P1	V0(+)	WHITE
P2		
SHIELD	GND(-)	BLACK
P3		
P4		

(Figure – Power Adapter Pin Assignment)

If you can not find this package or any items are missing, please contact AXIOMTEK distributors immediately.

***MEMO***

## CHAPTER 2

# HARDWARE INSTALLATION

The eBOX530-820-FL is convenient for your various hardware configurations, such as Memory Module, HDD (Hard Disk Drive), and CompactFlash™ card. The chapter 2 will show you how to install the hardware. It includes:

### 2.1 Installing the Memory Module

**Step 1** Turn off the system, and unplug the AC/DC power cord.

**Step 2** Turn the system upside down to locate screws at the bottom.



**Step 3** Loosen these screws, and remove the back cover from the system.



**Step 4** Locate the memory module as marked.



**Step 5** Hold one side of the module, and insert the gold colored contact into the socket. Push the module down.

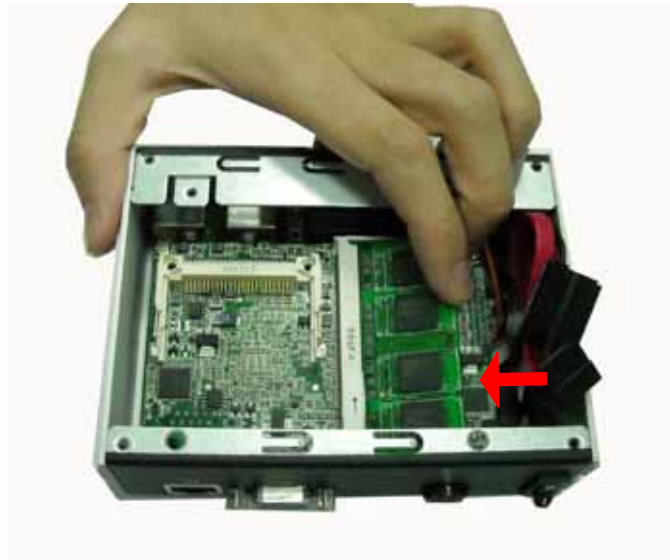

**Step 6** The memory module is locked by two latches on the sides.



 **NOTE** While uninstalling the Memory Module, you need to

*stretch these two latches aside, and then take the module off the socket.*

**Step 7** Put the cover back to the system, and fasten screws tight close the chassis.



## 2.2 Installing the Hard Disk Drive

### **\*\* NOTICE \*\***

Two graphics drivers, but only one can be installed in eBOX530.

- **Windows XP GMA 500 driver**

The default setting of display output under Windows XP GMA 500 driver is LVDS port. If you only connect VGA port to install driver, please press "**Ctrl+Alt+F1**" to switch the display output to VGA port.

- **Windows XP IEGD driver**

The **eBOX530-820-FL** offers a convenient drive bay module for users to install HDD. The system offers users one 2.5" Hard Disk Drive for installation. Please follow the steps:

The **eBOX530-820-FL** offers a convenient drive bay module for users to install HDD. The system offers users one 2.5" Hard Disk Drive for installation. Please follow the steps:

**Step 1** Turn off the system, and unplug the AC/DC power cord.

**Step 2** Turn the system upside down to locate screws at the bottom.



**Step 3** Loosen these screws, and remove the back cover from the system.



**Step 4** HDD assembly parts include:

- HDD Bracket x 1
- 2.5 inch HDD x 1
- Screws x 4
- HDD Mylar x1

Screw the 2.5 inch HDD, together with the HDD Mylar, to the HDD bracket.



- Step 5** Fix the HDD bracket into the system, and plug the power cable in HDD.



- Step 6** Put the cover back to the system, and fasten screws tight close the chassis.



## 2.3 Installing the CompactFlash™ Card

### \*\* NOTICE \*\*

Two graphics drivers, but only one can be installed in eBOX530.

- **Windows XP GMA 500 driver**

The default setting of display output under Windows XP GMA 500 driver is LVDS port. If you only connect VGA port to install driver, please press "**Ctrl+Alt+F1**" to switch the display output to VGA port.

- **Windows XP IEGD driver**

The **eBOX530-820-FL** offers a convenient drive bay module for users to install HDD. The system offers users one 2.5" Hard Disk Drive for installation. Please follow the steps:

**Step 1** Turn off the system, and unplug the AC/DC power cord.

**Step 2** Turn the system upside down to locate screws at the bottom.



**Step 3** Loosen these screws, and remove the back cover from the system.



**Step 4** Locate the CompactFlash™ socket.



**Step 5** Insert the CompactFlash™ card into the socket until it is firmly seated.



**Step 6** Put the cover back to the system, and fasten screws tight close the chassis.



## 2.4 Installing DIN Mount (optional)

The eBOX530-820-FL provides DIN Mount that customers can install as below:

**Step 1** Prepare DIN Mount assembling components (screws and bracket) ready.



**MAXIMUM DEPTH OF THE HDD BRACKET: 2.5mm**

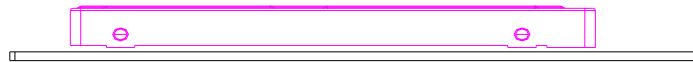

**DEPTH 2.5mm MAX.**

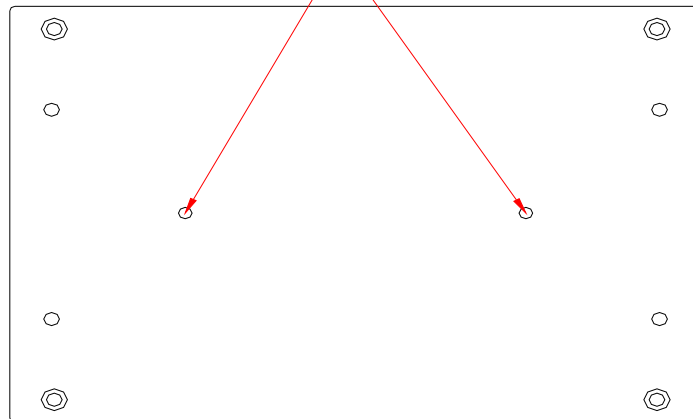

**Step 2** Assembly the bracket to the system, and fasten screws tight.



## **2.5 Installing Rail Mount**

The eBOX530-820-FL provides Rail Mount that customers can install as below:

**Step 1** Prepare Rail Mount assembling components (screws and bracket) ready.



**Step 2** Assembly the bracket to the system, and fasten screws tight.



***MEMO***

## CHAPTER 3

# PHOENIX-AWARD BIOS UTILITY

The Phoenix-Award BIOS provides users with a built-in Setup program to modify basic system configuration. All configured parameters are stored in a battery-backed-up RAM (CMOS RAM) to save the Setup information whenever the power is turned off.

### 3.1 Entering Setup

There are two ways to enter the Setup program. You may either turn ON the computer and press <Del> immediately, or press the <Del> and/or <Ctrl>, <Alt>, and <Esc> keys simultaneously when the following message appears at the bottom of the screen during POST (Power on Self Test).

TO ENTER SETUP PRESS DEL KEY

If the message disappears before you respond and you still want to enter Setup, please restart the system to try it again. Turning the system power OFF and ON, pressing the "RESET" button on the system case or simultaneously pressing <Ctrl>, <Alt>, and <Del> keys can restart the system. If you do not press keys at the right time and the system doesn't boot, an error message will pop out to prompt you the following information:

PRESS <F1> TO CONTINUE, <CTRL-ALT-ESC> OR <DEL> TO ENTER SETUP

## 3.2 Control Keys

<b>Up arrow</b>	Move cursor to the previous item
<b>Down arrow</b>	Move cursor to the next item
<b>Left arrow</b>	Move cursor to the item on the left hand
<b>Right arrow</b>	Move to the item in the right hand
<b>Esc key</b>	Main Menu -- Quit and delete changes into CMOS Status Page Setup Menu and Option Page Setup Menu -- Exit current page and return to Main Menu
<b>PgUp/"+" key</b>	Increase the numeric value or make changes
<b>PgDn/"-" key</b>	Decrease the numeric value or make changes
<b>F1 key</b>	General help, only for Status Page Setup Menu and Option Page Setup Menu
<b>(Shift) F2 key</b>	Change color from total 16 colors. F2 to select color forward, (Shift) F2 to select color backward
<b>F3 key</b>	Reserved
<b>F4 key</b>	Reserved
<b>F5 key</b>	Restore the previous CMOS value from CMOS, only for Option Page Setup Menu
<b>F6 key</b>	Load the default CMOS value from BIOS default table, only for Option Page Setup Menu
<b>F7 key</b>	Load the Setup default, only for Option Page Setup Menu
<b>F8 key</b>	Reserved
<b>F9 key</b>	Reserved
<b>F10 key</b>	Save all the CMOS changes, only for Main Menu

## 3.3 Getting Help

- **Main Menu**  
The online description of the highlighted setup function is displayed at the bottom of the screen.
- **Status Page Setup Menu/Option Page Setup Menu**  
Press <F1> to pop out a small Help window that provides the description of using appropriate keys and possible selections for highlighted items. Press <F1> or <Esc> to exit the Help Window.

### 3.4 The Main Menu

Once you enter the Award BIOS CMOS Setup Utility, the Main Menu will appear on the screen. The Main Menu allows you to select from ten setup functions and two exit choices. Use the arrow keys to select the setup function you intend to configure then press <Enter> to accept or enter its sub-menu.

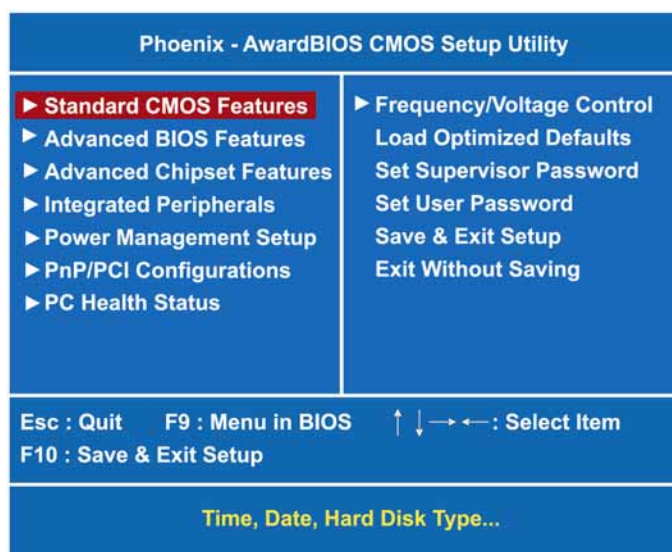

 **NOTE** If you find that your computer cannot boot after making and saving system changes with Setup, the Award BIOS, via its built-in override feature, resets your system to the CMOS default settings.

We strongly recommend that you avoid making any changes to the chipset defaults. These defaults have been carefully chosen by both Phoenix-Award and your system manufacturer to provide the absolute maximum performance and reliability.

### 3.5 Standard CMOS Setup Menu

The items in Standard CMOS Setup Menu are divided into several categories. Each category includes no, one or more than one setup items. Use the arrow keys to highlight the item and then use the <PgUp> or <PgDn> keys to select the value you want in each item.

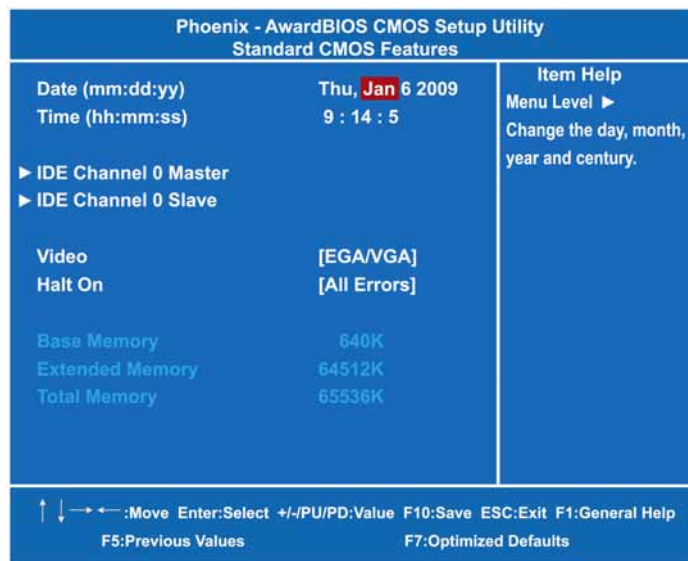

- Date**  
 The date format is <day>, <date> <month> <year>. Press <F3> to show the calendar.

<b>day</b>	The day of week, from Sun to Sat, determined by the BIOS, is read only
<b>date</b>	The date, from 1 to 31 (or the maximum allowed in the month), can key in the numerical / function key
<b>month</b>	The month, Jan through Dec.
<b>year</b>	The year, depends on the year of BIOS

- Time**  
 The time format is <hour> <minute> <second> accepting either functions key or numerical key. The time is calculated based on the 24-hour military-time clock. For example, 1 p.m. is 13:00:00.
- IDE Channel 0 Master/Slave**

The categories identify the types of one channel that have been installed in the computer. There are 45 predefined types and 2 users definable types are for Enhanced IDE BIOS. Type 1 to Type 45 is predefined. Type User is user-definable.

Press <PgUp>/<+> or <PgDn>/<-> to select a numbered hard disk type or type the number and press <Enter>. Note that the specifications of your drive must match with the drive table. The hard disk will not work properly if you enter improper information within this category. If your hard disk drive type does not match or is not listed, you can use Type User to define your own drive type manually.

If you select Type User, related information is asked to be entered to the following items. Enter the information directly from the keyboard and press <Enter>. This information should be provided in the documentation from your hard disk vendor or the system manufacturer.

If the controller of HDD interface is ESDI, select "Type 1".

If the controller of HDD interface is SCSI, select "None".

If the controller of HDD interface is CD-ROM, select "None".

<b>CYLS.</b>	number of cylinders	<b>LANDZONE</b>	landing zone
<b>HEADS</b>	number of heads	<b>SECTORS</b>	number of sectors
<b>PRECOMP</b>	write precom	<b>MODE</b>	HDD access mode

If there is no hard disk drive installed, select NONE and press <Enter>.

- **Video**

Select the display adapter type for your system.

- **Halt On**

This field determines whether the system will halt if an error is detected during power up.

<b>No errors</b>	The system boot will halt on any error detected. (default)
<b>All errors</b>	Whenever the BIOS detect a non-fatal error, the system will stop and you will be prompted.
<b>All, But Keyboard</b>	The system boot will not stop for a keyboard error; it will stop for all other errors.
<b>All, But Diskette</b>	The system boot will not stop for a disk error; it will stop for all other errors.

<b>All, But Disk/Key</b>	The system boot will not stop for a keyboard or disk error; it will stop for all other errors.
--------------------------	--

Press <Esc> to return to the Main Menu page.

### 3.6 Advanced BIOS Features

This section allows you to configure and improve your system and allows you to set up some system features according to your preference.



- **CPU Feature**

Scroll to this item and press <Enter> to view the CPU Feature sub menu.

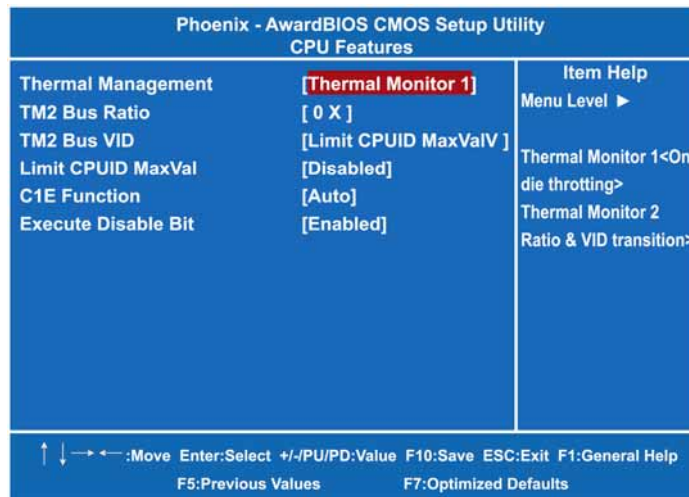

- **Hard Disk Boot Priority**

Scroll to this item and press <Enter> to view the sub menu to decide the disk boot priority.

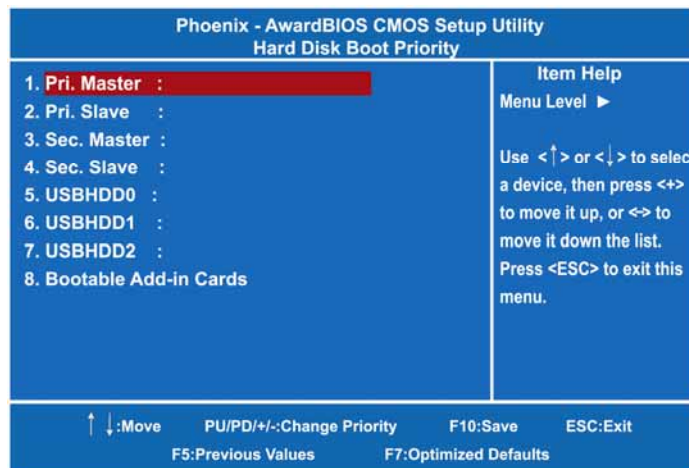

Press <Esc> to return to the Advanced BIOS Features page.

- **Quick Power On Self Test**

This option speeds up Power on Self Test (POST) after you turn on the system power. If set as Enabled, BIOS will shorten or skip some check items during POST. The default setting is "Enabled".

<b>Enabled</b>	Enable Quick POST
<b>Disabled</b>	Normal POST

- **First/Second/Third Boot Device**

These items allow the selection of the 1<sup>st</sup>, 2<sup>nd</sup>, and 3<sup>rd</sup> devices that the system will search for during its boot-up sequence. The wide range of selection is available.

- **Boot Other Device**

This item allows the user to enable/disable the boot device not listed on the First/Second/Third boot devices option above. The default setting is "Enabled".

- **Boot Up NumLock Status**

Set the Num Lock status when the system is powered on. The default value is "On".

- **Security Option**

This item allows you to limit access to the system and Setup, or just to Setup. The default value is "Setup".

<b>System</b>	The system will not boot and access to Setup will be denied if the incorrect password is entered at the prompt.
<b>Setup</b>	The system will boot, but access to Setup will be denied if the correct password is not entered at the prompt.



**NOTE** To disable security, select PASSWORD SETTING at Main Menu and then you will be asked to enter password. Do not type anything, just press <Enter> and it will disable security. Once the security is disabled, the system will boot and you can enter Setup freely.

- **APIC Mode**

Use this item to enable or disable APIC (Advanced Programmable Interrupt Controller) mode that provides symmetric multi-processing (SMP) for systems.

- **MPS Version Control For OS**

This item specifies the version of the Multiprocessor Specification (MPS). Version 1.4 has extended configuration tables to improve support for multiple PCI bus configurations and provide future expandability.

Press <Esc> to return to the Main Menu page.

### 3.7 Advanced Chipset Features

Since the features in this section are related to the chipset on the CPU board and are completely optimized, you are not recommended to change the default settings in this setup table unless you are well oriented with the chipset features.

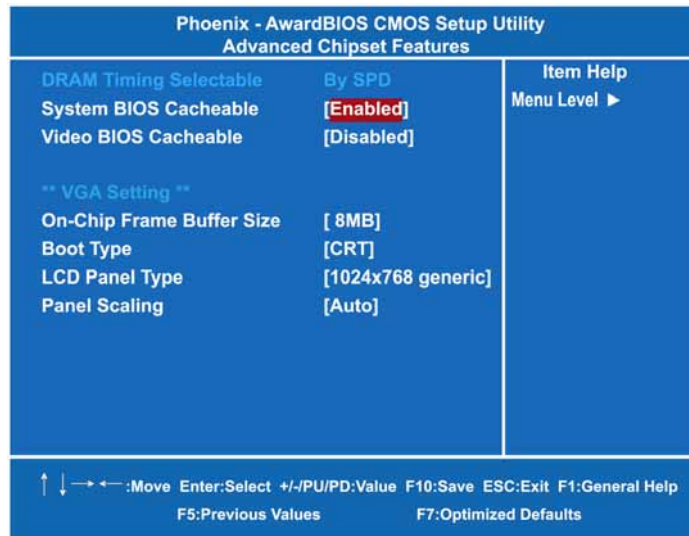

- **DRAM Timing Selectable**

Use this item to increase the timing of the memory. This is related to the cooling of memory

- **System BIOS Cacheable**

Selecting Enabled allows caching of the system BIOS ROM at F0000h-FFFFFh, resulting in better system performance. However, if any program writes to this memory area, a system error may

result. The default value is "Disabled".

- **Video BIOS Cacheable**  
This item allows you to change the Video BIOS location from ROM to RAM. Video Shadow will increase the video speed.

\*\*\* **VGA Setting** \*\*\*

- **On-Chip Frame Buffer Size**  
Use this item to set the VGA frame buffer size.
- **Boot Type**  
This item is to select Display Device that the screen will be shown.
- **Panel Scaling**  
This item shows the setting of panel scaling and operates the scaling function that the panel output can fit the screen resolution connected to the output port.

Press <Esc> to return to the Main Menu page.

### 3.8 Integrated Peripherals

This section allows you to configure your OnChip IDE Device, Onboard Device and SuperIO Device.

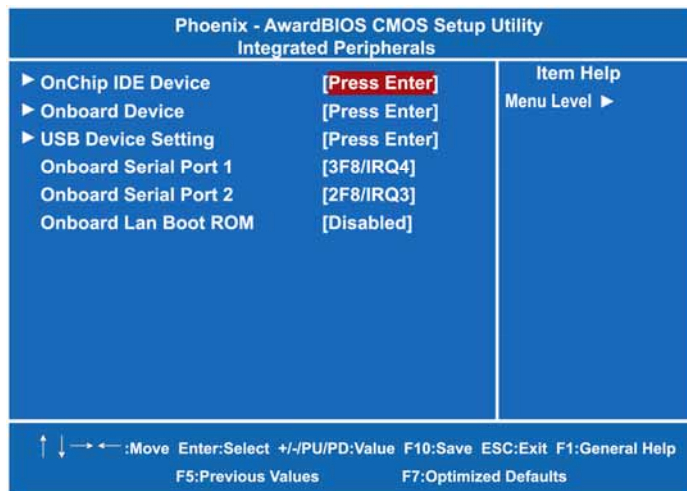

- **OnChip IDE Device**  
Scroll to this item and press <Enter> to view the sub menu OnChip IDE Device.

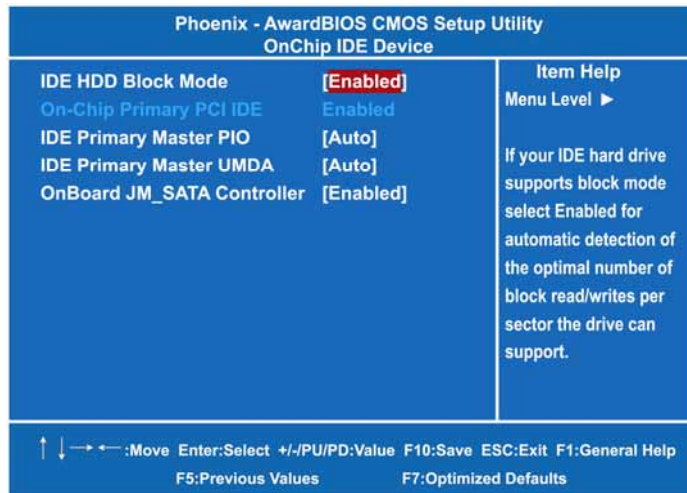

➤ **IDE HDD Block Mode**

Block mode is also called block transfer, multiple commands, or multiple sectors read/write. If your IDE hard drive supports block mode (most new drives do), select Enabled for automatic detection of the optimal number of block read/writes per sector the drive can support.

Press <Esc> to return to the Integrated Peripherals page.

● **Onboard Device**

Scroll to this item and press <Enter> to view the sub menu Onboard Device.

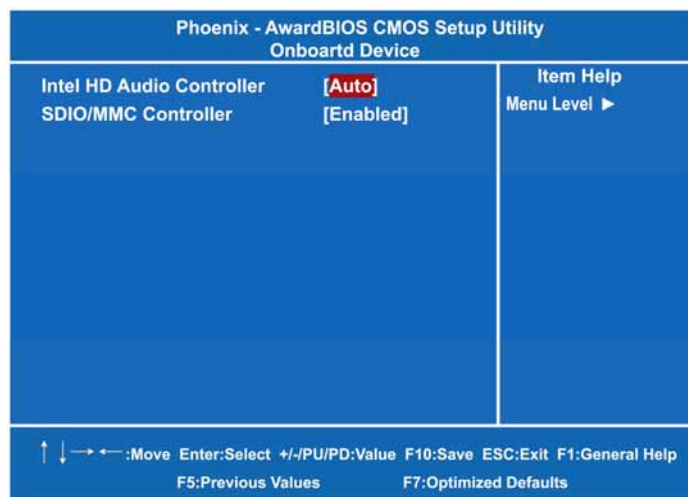

➤ **Intel HD Audio Controller**

Use this item to enable an Intel HD Audio controller for interfacing the device with a LAN.

Press <Esc> to return to the Integrated Peripherals page.

- **USB Device Setting**

Scroll to this item and press <Enter> to view the sub menu USB Device Setting.

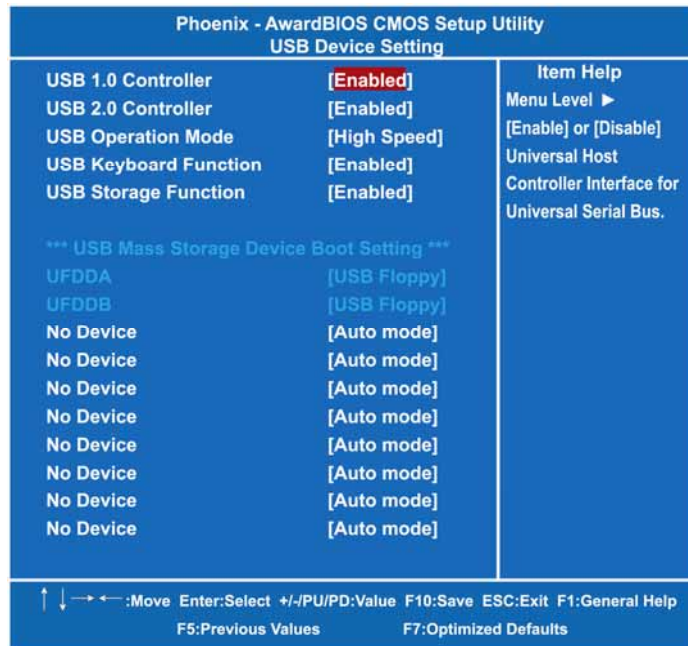

- **Onboard Serial Port 1/2**

Select an address and corresponding interrupt for the serial port. There are several options for your selection.

- **Onboard Lan Boot ROM**

Use this item to enable or disable the Boot ROM function of the onboard LAN chip when the system boots up.

### 3.9 Power Management Setup

The Power Management Setup allows you to save energy of your system effectively. It will shut down the hard disk and turn OFF video display after a period of inactivity.

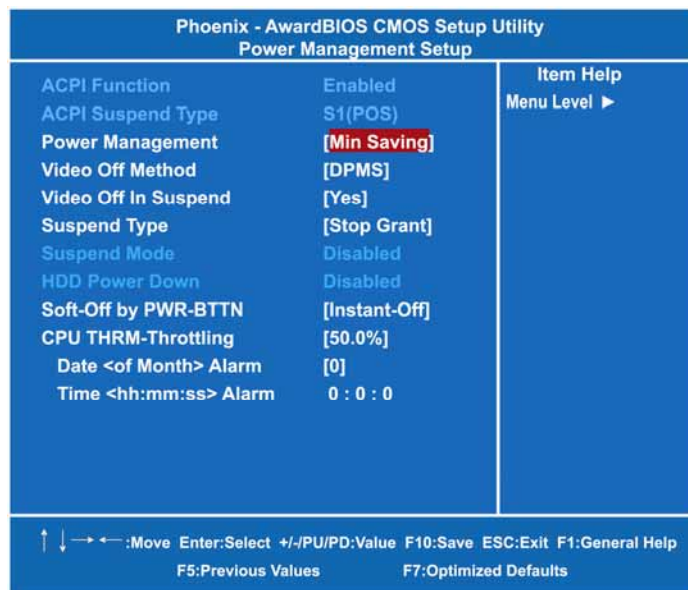

- ACPI Function**  
 This item allows you to enable/disable the Advanced Configuration and Power Management (ACPI). The function is always “*Enabled*”.
- ACPI Suspend Type**  
 This item specifies the power saving modes for ACPI function. If your operating system supports ACPI, such as Windows 98SE, Windows ME and Windows 2000, you can choose to enter the Standby mode in S1 (POS) or S3 (STR) fashion through the setting of this field. Options are:

[S1(POS)] The S1 sleep mode is a low power state. In this state, no system context is lost (CPU or chipset) and hardware maintains all system contexts.

[S3(STR)] The S3 sleep mode is a lower power state where the information of system configuration and open applications/files is saved to main memory that remains

powered while most other hardware components turn off to save energy. The information stored in memory will be used to restore the system when a “wake up” event occurs.

- **Power Management**

This option allows you to select the type (or degree) of power saving for Doze, Standby, and Suspend modes. The table below describes each power management mode:

<b>Max Saving</b>	It is maximum power savings, only available for SL CPUs. The inactivity period is 1 minute in each mode.
<b>User Define</b>	It sets each mode. Select time-out periods in the PM Timers section.
<b>Min Saving</b>	It is minimum power savings. The inactivity period is 1 hour in each mode (except the hard drive).
<b>Disabled</b>	Default value

- **Video Off Method**

This setting determines the manner in which the monitor is blanked.

<b>V/H SYNC+Blank</b>	Turns OFF vertical and horizontal synchronization ports and writes blanks to the video buffer
<b>DPMS</b>	Select this option if your monitor supports the Display Power Management Signaling (DPMS) standard of the Video Electronics Standards Association (VESA). Use the software supplied for your video subsystem to select video power management values.
<b>Blank Screen</b>	System only writes blanks to the video buffer.

- **Video Off In Suspend**

This item defines if the video is powered down when the system is put into suspend mode.

- **Suspend Type**

If this item is set to the default Stop Grant, the CPU will go into Idle Mode during power saving mode.

- **Suspend Mode**

After the selected period of system inactivity (1 minute to 1 hour), all devices except the CPU shut off. The default value is "Disabled".

<b>Disabled</b>	System will never enter SUSPEND mode
<b>1/2/4/6/8/10/20/30/40 Min/1 Hr</b>	Defines the continuous idle time before the system entering SUSPEND mode. If any item defined in (J) is enabled & active, SUSPEND timer will be reloaded

- **HDD Power Down**

If HDD activity is not detected for the length of time specified in this field, the hard disk drive will be powered down while all other devices remain active.

- **Soft-Off by PWR-BTTN**

This option only works with systems using an ATX power supply. It also allows the user to define which type of soft power OFF sequence the system will follow. The default value is "Instant-Off".

<b>Instant-Off</b>	This option follows the conventional manner systems perform when power is turned OFF. Instant-Off is a soft power OFF sequence requiring only the switching of the power supply button to OFF
<b>Delay 4 Sec.</b>	Upon turning OFF system from the power switch, this option will delay the complete system power OFF sequence by approximately 4 seconds. Within this delay period, system will temporarily enter into Suspend Mode enabling you to restart the system at once.

Press <Esc> to return to the Main Menu page.

### 3.10 PnP/PCI Configuration Setup

This section describes configuring the PCI bus system. PCI, or Personal Computer Interconnect, is a system which allows I/O devices to operate at speeds nearing the speed the CPU itself uses when communicating with its own special components. This section covers some very technical items and it is strongly recommended that only experienced users should make any changes to the default settings.

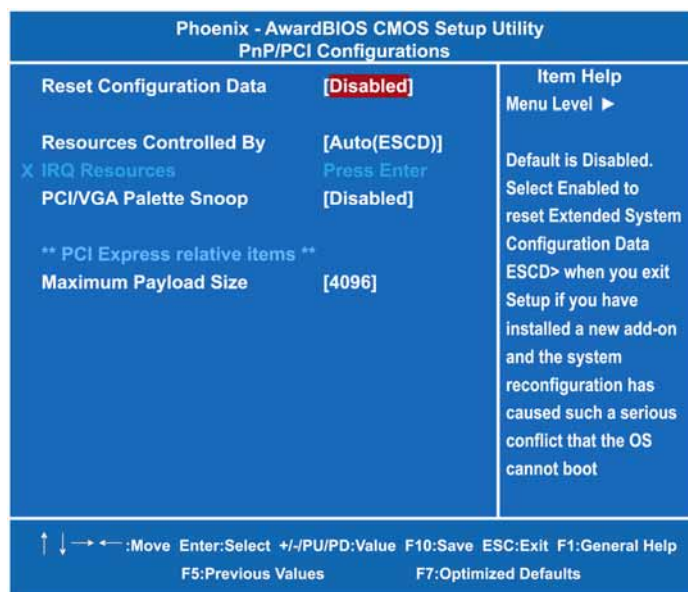

- Reset Configuration Data**  
 Normally, you leave this item Disabled. Select Enabled to reset Extended System Configuration Data (ESCD) when you exit Setup or if installing a new add-on cause the system reconfiguration a serious conflict that the operating system can not boot. Options: Enabled, Disabled.
- Resources Controlled By**  
 The Award Plug and Play BIOS can automatically configure all boot and Plug and Play-compatible devices. If you select Auto, all interrupt request (IRQ), DMA assignment, and Used DMA fields disappear, as the BIOS automatically assigns them. The default value is "Manual".

- **IRQ Resources**

When resources are controlled manually, assign each system interrupt to one of the following types in accordance with the type of devices using the interrupt:

1. Legacy ISA Devices compliant with the original PC AT bus specification, requiring a specific interrupt (such as IRQ4 for serial port 1).
2. PCI/ISA PnP Devices compliant with the Plug and Play standard, whether designed for PCI or ISA bus architecture.

The default value is "*PCI/ISA PnP*".

- **PCI/VGA Palette Snoop**

Some non-standard VGA display cards may not show colors properly. This item allows you to set whether MPEG ISA/VESA VGA Cards can work with PCI/VGA or not. When enabled, a PCI/VGA can work with a MPEG ISA/VESA VGA card; when disabled, a PCI/VGA cannot work with a MPEG ISA/VESA Card.

**\*\* PCI Express relative items \*\***

- **Maximum Payload Size**

When using DDR SDRAM and Buffer size selection, another consideration in designing a payload memory is the size of the buffer for data storage. Maximum Payload Size defines the maximum TLP (Transaction Layer Packet) data payload size for the device.

Press <Esc> to return to the Main Menu page.

### 3.11 PC Health Status

This section supports hardware monitoring that lets you monitor those parameters for critical voltages, temperatures and fan speed of the board.

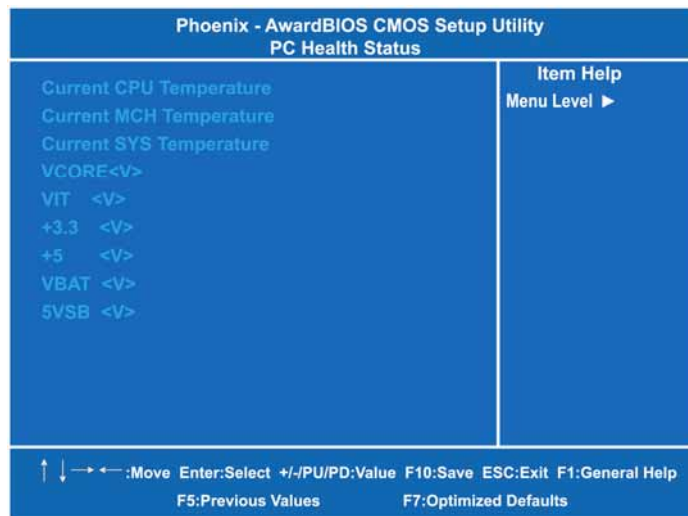

- **System Component Characteristics**

These items provide you with information about the system's current operating status. You can't change these items.

1. Current CPU Temperature
2. Current MCH Temperature
3. Current System Temperature
4. VCORE/VIT/VBAT/5VSB

Press <Esc> to return to the Main Menu page.

### 3.12 Frequency/Voltage Control

This section is to control the CPU frequency and Supply Voltage, DIMM OverVoltage and AGP voltage.

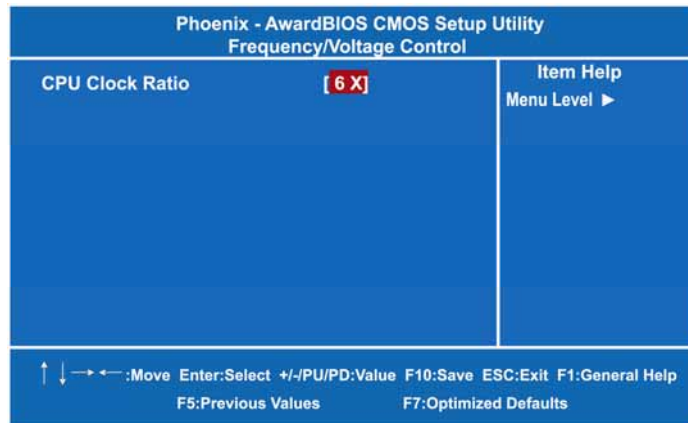

- **CPU Clock Ratio**  
Use this item to select the CPU's frequency.

Press <Esc> to return to the Main Menu page.

### 3.13 Load Optimized Defaults

This option allows you to load the default values to your system configuration. These default settings are optimal and enable all high performance features.

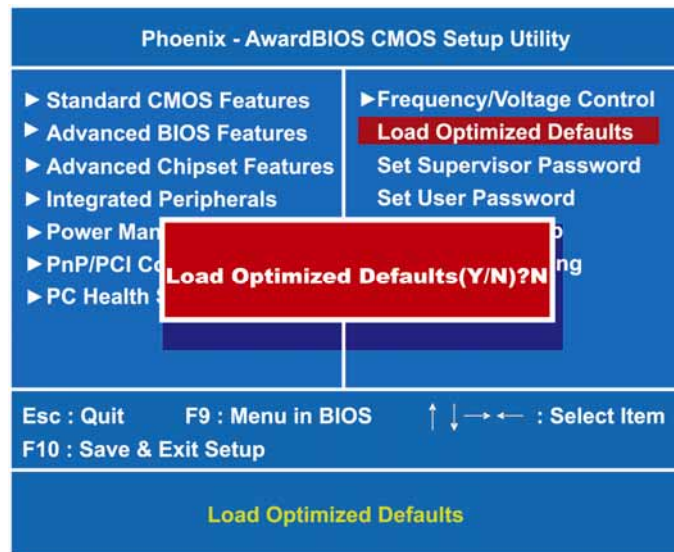

To load SETUP defaults value to CMOS SRAM, enter "Y". If not, enter "N".

### 3.14 Set Supervisor/User Password

You can set a supervisor or user password, or both of them. The differences between them are:

1. **Supervisor password:** You can enter and change the options on the setup menu.
2. **User password:** You can just enter, but have no right to change the options on the setup menu.

When you select this function, the following message will appear at the center of the screen to assist you in creating a password.

#### **ENTER PASSWORD**

Type a maximum eight-character password, and press <Enter>. This typed password will clear previously entered password from the CMOS memory. You will be asked to confirm this password. Type this password again and press <Enter>. You may also press <Esc> to abort this selection and not enter a password.

To disable the password, just press <Enter> when you are prompted to enter a password. A message will confirm the password is getting disabled. Once the password is disabled, the system will boot and you can enter Setup freely.

#### **PASSWORD DISABLED**

When a password is enabled, you have to type it every time you enter the Setup. It prevents any unauthorized persons from changing your system configuration.

Additionally, when a password is enabled, you can also require the BIOS to request a password every time the system reboots. This would prevent unauthorized use of your computer.

You decide when the password is required for the BIOS Features Setup Menu and its Security option. If the Security option is set to "System", the password is required during booting up and entry into the Setup; if it is set as "Setup", a prompt will only appear before entering the Setup.

### 3.15 Save & Exit Setup

This allows you to determine whether or not to accept the modifications. Typing "Y" quits the setup utility and saves all changes into the CMOS memory. Typing "N" brings you back to Setup utility.

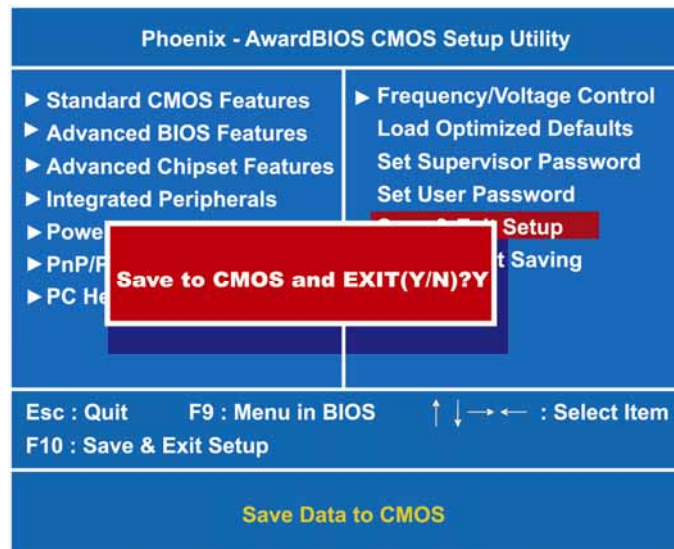

### 3.16 Exit Without Saving

Select this option to exit the Setup utility without saving the changes you have made in this session. Typing “Y” will quit the Setup utility without saving the modifications. Typing “N” will return you to Setup utility.

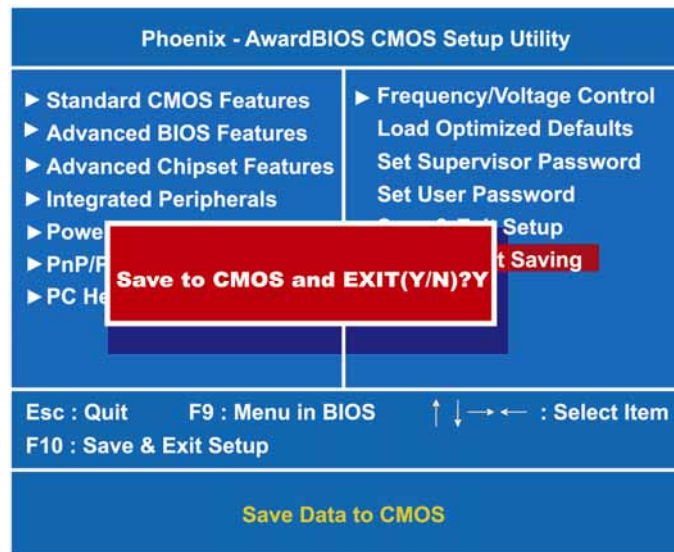

## CHAPTER 4 INSTALLATION OF DRIVERS

The device drivers are located on the Product Information CD-ROM that comes with the package. The auto-run function of drivers will guide you to install the utilities and device drivers under a Windows system. You can follow the onscreen instructions to install these devices:

- Chipset
- VGA
- LAN
- Audio

### 4.1 Installing Chipset Driver

1. Run the SETUP.EXE program from the driver directory in your driver CD. Click "Next" to next step.



- An Intel® License Agreement appears to show you the important information. Click "Yes" to next step.



- Please wait while running the following setup operations.



(3-1)



(3-2)

4. Click "Finish" to complete the setup process.



5. You will be asked to reboot your computer when the installation is completed. Please click "Yes, I want to restart my computer now" if you don't need to install any other drivers. Otherwise, please click "No, I will restart my computer later", and go on next step.

## 4.2 Installing VGA Driver

### \*\* NOTICE \*\*

- **Windows XP GMA 500 driver**

The default setting of display output under Windows XP GMA 500 driver is LVDS port. If you only connect VGA port to install driver, please press "**Ctrl+Alt+F1**" to switch the display output to VGA port.

1. Run the SETUP.EXE program from the driver directory in your driver CD. Click "Next" to next step.

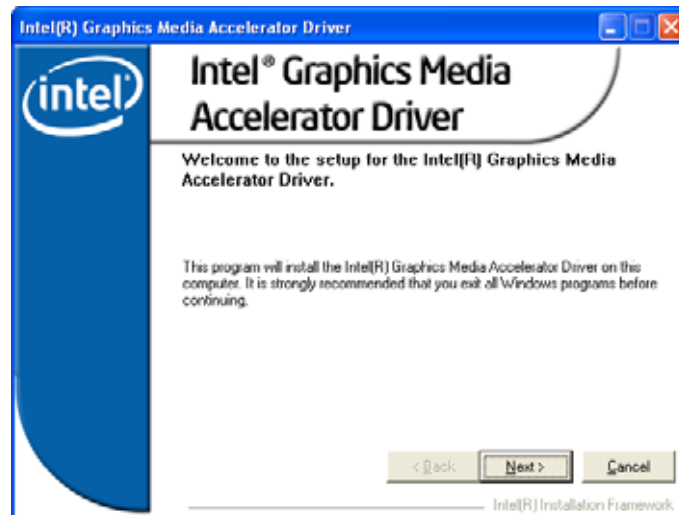

- An Intel® License Agreement appears to show you the important information. Click "Yes" to next step.

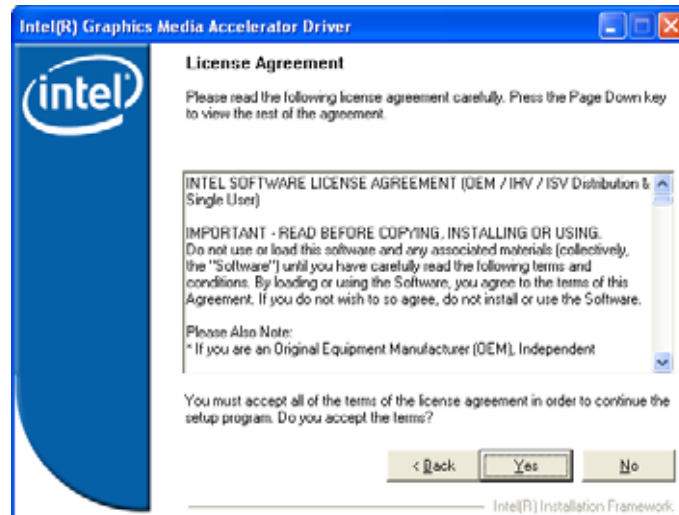

- The message of Readme File Information appears to show you the system requirements and installation information. Please click "Next".

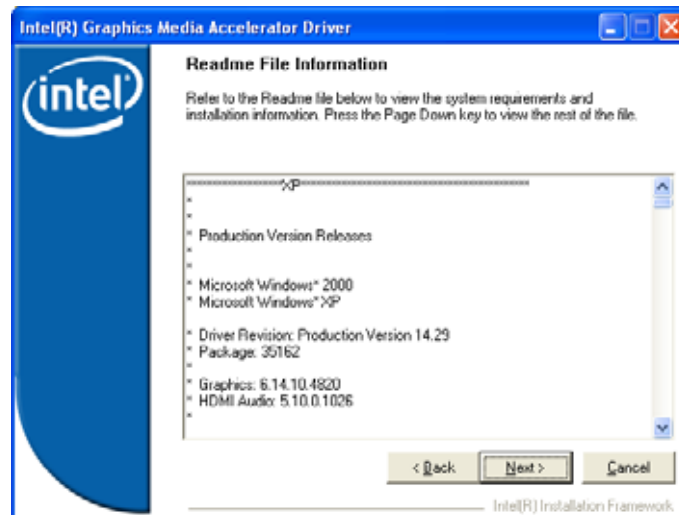

4. Please wait while running the following setup operations.

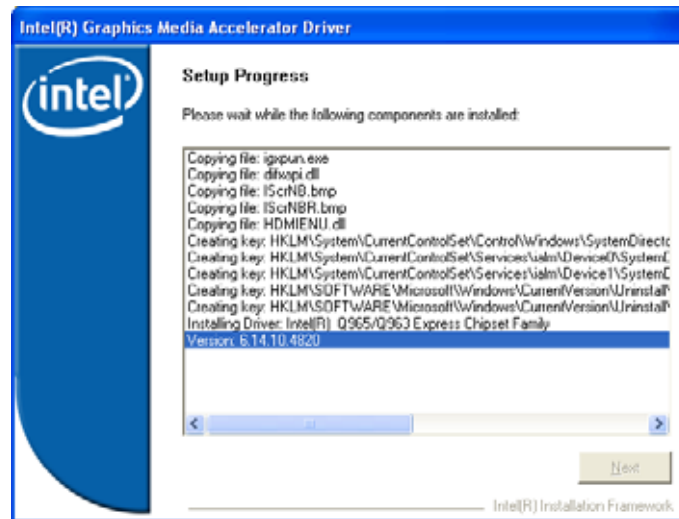

5. When this message appears, please click “Next”.

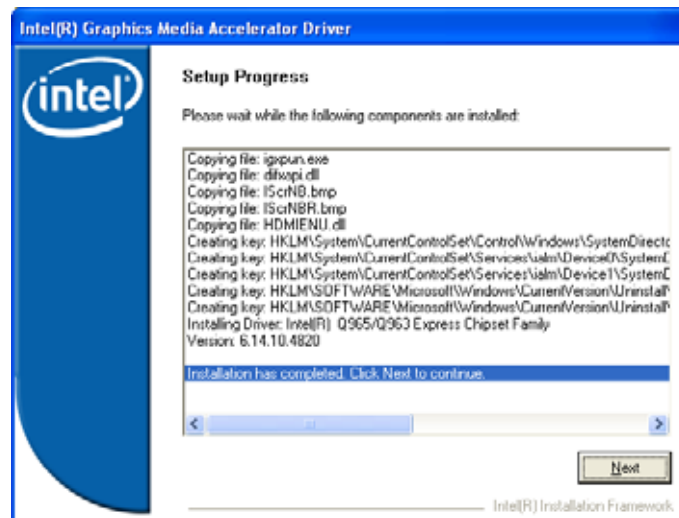

6. You will be asked to reboot your computer when the installation is completed. Please click “Yes, I want to restart my computer now” if you don’t need to install any other drivers. Otherwise, please click “No, I will restart my computer later”, and click “Finish” to complete the installation.

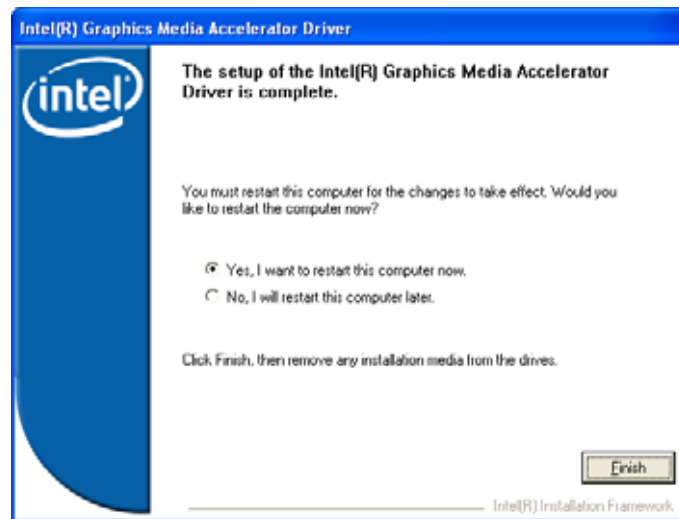

### 4.3 Installing LAN Driver

1. Run the InstallShield Wizard for Ethernet from the driver directory in your driver CD. Click "Next" to next step.

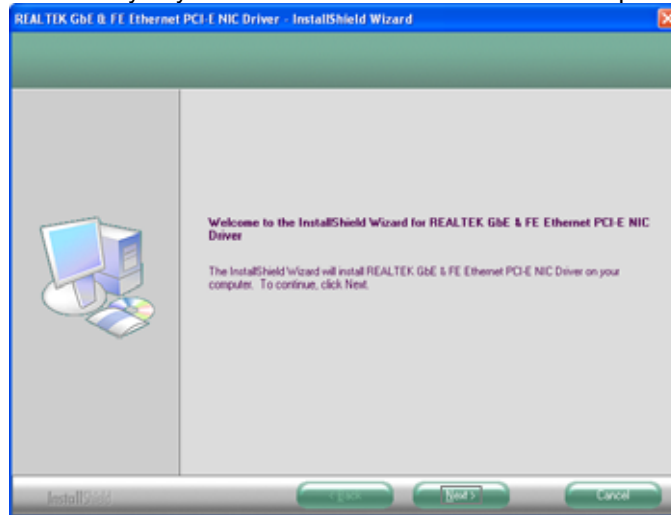

2. Click "Install" to start the installation.

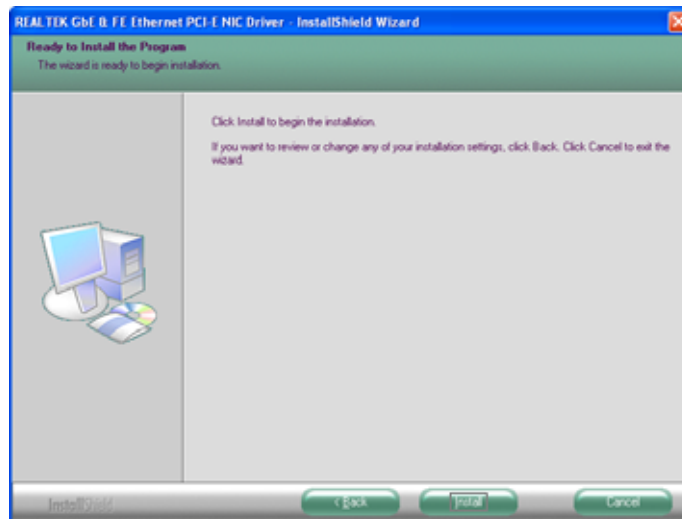

3. Please wait while running the following installation operation.

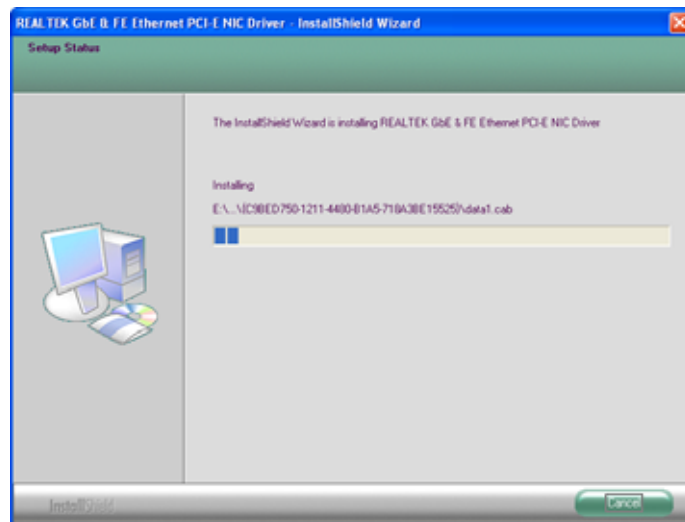

4. Click "Finish" to complete the installation.

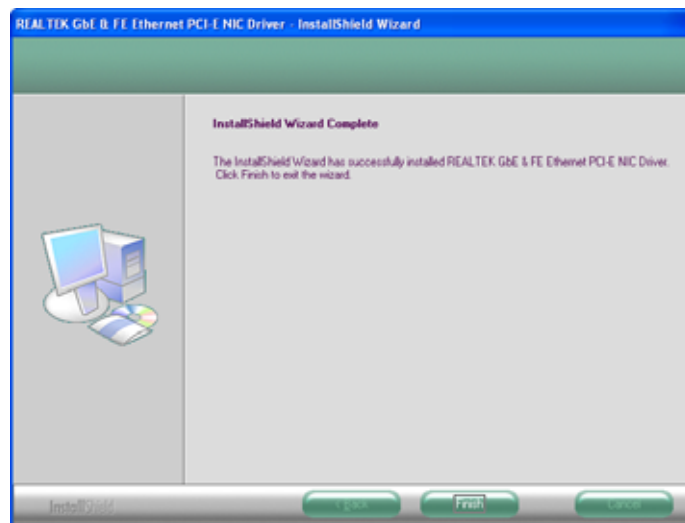

## 4.4 Installing Audio Driver

1. Run the InstallShield Wizard for Audio from the driver directory in your driver CD. Click "Next" to next step.



2. Please wait while running the following installation operation.



3. You will be asked to reboot your computer when the installation is completed. Please click “Yes, I want to restart my computer now” if you don’t need to install any other drivers. Otherwise, please click “No, I will restart my computer later”, and click “Finish” to complete the installation.

