

eBOX530-820-FL Quick Installation Guide

V. Installing the Hard Disk Drive

Step 1 Turn off the system, and unplug the power cord.

Step 2 Turn the system upside down to locate screws at the bottom, loosen screws to remove the back cover.

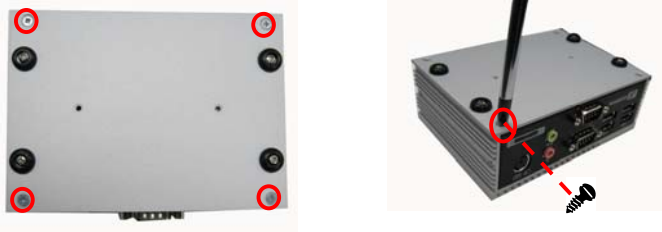

Step 3 Assembly the HDD bracket, together with the HDD Mylar, and fix it all into the system, and plug the power cable in HDD.



Step 4 Close the cover to the chassis, and fasten all screws.

! **MAXIMUM DEPTH OF THE HDD BRACKET : 2.5mm (when installing DIN Mount)**

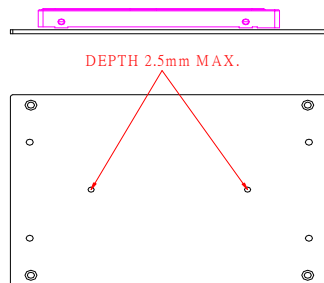

©Copyright 2009 AXIOMTEK Co., Ltd.
Version A2 April 2009
Printed in Taiwan
94260530020E

eBOX530-820-FL Quick Installation Guide

I. Packing List

| | |
|---|---|
| ✓ eBOX530-820-FL System Unit x 1 | ✓ Y Cable for PS/2 Keyboard & Mouse x 1 |
| ✓ eBOX530-820-FL Quick Installation Guide x 1 | ✓ CD x 1 (for Driver and SBC User's Manual) |
| ✓ Power Cord x 1 | ✓ 25W 5V AC/DC Power Adapter x 1 |
| ✓ Wallmount Bracket x 2 | ✓ NOTICE x1 |
| ✓ M3x4 Screws x 4 | ✓ HDD Mylar x1 |

➤ **Do not try to apply power to the system if any damaged components.**

II. Dimensions

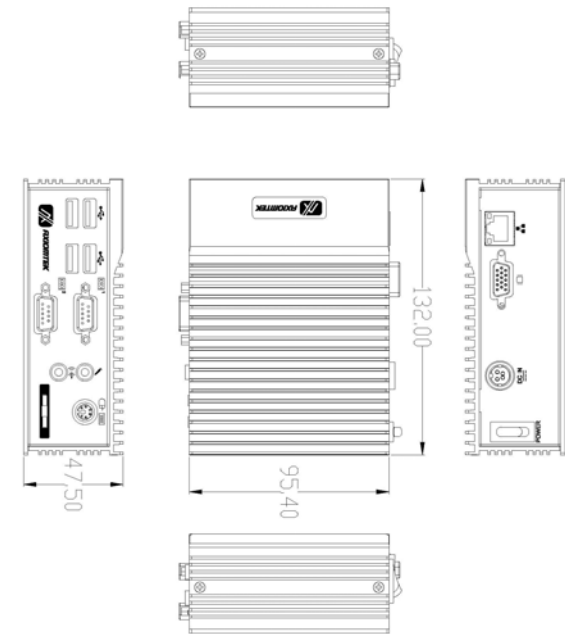

©Copyright 2009 AXIOMTEK Co., Ltd.
Version A2 April 2009
Printed in Taiwan
94260530020E

eBOX530-820-FL Quick Installation Guide

III. I/O Outlets

The following figures show you I/O outlets on front and rear panels of the eBOX530-820-FL Series.

Front View

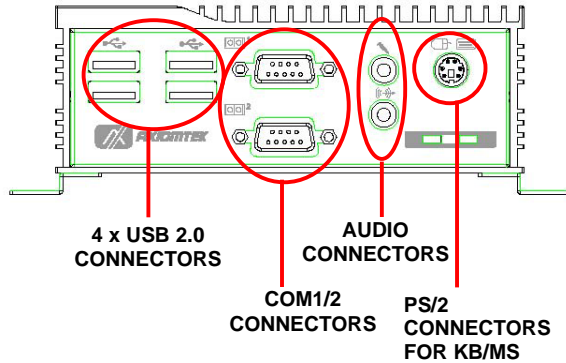

Rear View

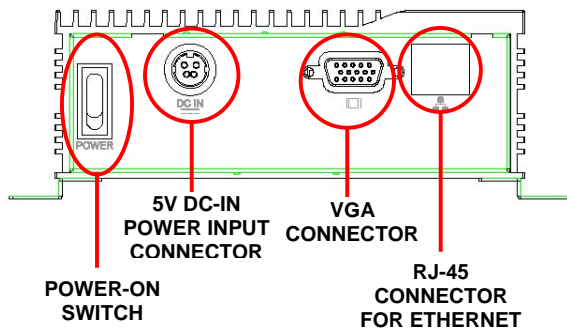

eBOX530-820-FL Quick Installation Guide

IV. Installing the Memory Module

Step 1 Turn off the system, and unplug the power cord.

Step 2 Turn the system upside down to locate screws at the bottom, loosen screws to remove the back cover.



Step 3 Locate the memory module, insert the gold colored contact into the socket. Push the module down, until it is firmly seated by locking two latches on the sides.

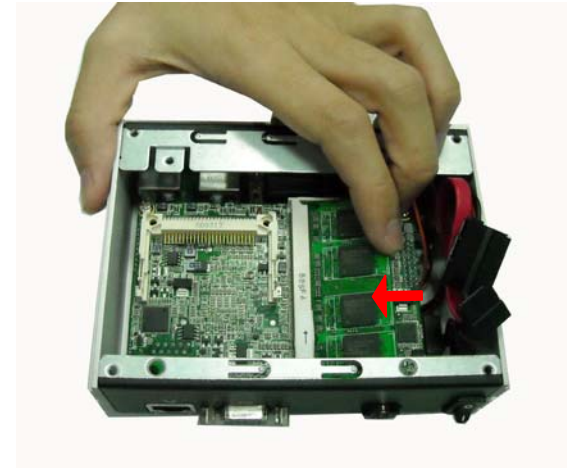

Step 4 Close the cover to the chassis, and fasten all screws.

All Components are fragile and sensitive. If you need to replace or return any components for repair, you must contact authorized technicians for a professional handling.

There is a User's Manual CD-ROM for the CPU card installed in your eBOX530-820-FL system. Please consult your local vendor for assistance if you have any difficulties in installing.