

■ Value SATA-II SSD with MLC Flash



VSSDs deliver all the advantages of solid state storage without the high sticker price most SSDs carry, which means you get performance and reliability on a budget. With no moving parts, VSSDs are exceptionally rugged compared to HDDs, enjoying far superior resistance to shock and vibration.

Super Talent VSSD offers shorter OS bootup time, faster application loading, less system power consumption and a brand new experience the customer can never get from traditional hard-disks. VSSD takes full advantage of the 3Gbps SATA-II bandwidth. The VSSD is capable of sequential read speeds up to 150 MB/sec and sequential write speeds up to 100 MB/sec.

Available in capacities from 8GB to 64GB, Super Talent provides customers the option to enter the SSD world with a limited budget, but no compromise in performance. Customers can now build or upgrade a system economically, running the operating system and applications on the VSSD and storing data on a traditional hard-disk.

Physical Specifications

Form Factor	2.5"
Capacity*	8GB - 64GB
Dimension	69.85 x 100.20 x 9.50 mm
SATA Interface	Serial ATA-II 3Gbps
NAND Flash	MLC
Power Supply	5V ± 10%
Package	Protective polymer casing

Environmental Specifications

Operating Shock	1500G
Operating Vibration	16G
Operating Temp.	0°C to +70°C

Performance Specifications

	Seq. Read (max)	Seq. Write (max)
8GB	60 MB/sec	20 MB/sec
16GB	90 MB/sec	30 MB/sec
32GB	90 MB/sec	30 MB/sec
64GB	150 MB/sec	60 MB/sec

Reliability Specifications

MTBF	1,000,000 hours
Data Reliability	Built-in EDC/ECC function
Data Retention	5 years
Wear Leveling Algor.	Patent Pending

Ordering Information

8GB	FTM8GL25V
16GB	FTM16GL25V
32GB	FTM32GL25V
64GB	FTM64GL25V

© 2010 Super Talent Technology. Specifications subject to change without notice. US patent # 6,547,130 and others apply. Usable capacity may be less than specified after formatting. Performance is highly dependent upon test environment and use case. Consult our benchmarking data for more detailed performance information or benchmark performance in your environment.

■ ■ Value SATA-II SSD with MLC Flash

SATA Flash Drive Pin Assignment

Power Segment

PIN	Signal Name	Description
P1	Not Used (3.3V)	N/A
P2	Not Used (3.3V)	N/A
P3	Not Used (3.3V Precharge)	
P4	GND	1 st mate
P5	GND	2 nd mate
P6	GND	
P7	5V Precharge	5V Power
P8	5V Precharge	5V Power
P9	5V Precharge	
P10	GND	
P11	Reserved	
P12	GND	1 st mate
P13	Not Used (12V Precharge)	N/A
P14	Not Used (12V)	
P15	Not Used (12V)	

Signal Segment

PIN	Signal Name	Description
S1	GND	
S2	RxP	Differential Signal pair for Receive
S3	RxN	
S4	GND	
S5	TxN	Differential Signal pair for Transmit
S6	TxP	
S7	GND	

Revision History

April 14, 2010

Rev-A Product Specification Released

■ Value SATA-II SSD with MLC Flash

Mechanical Specifications

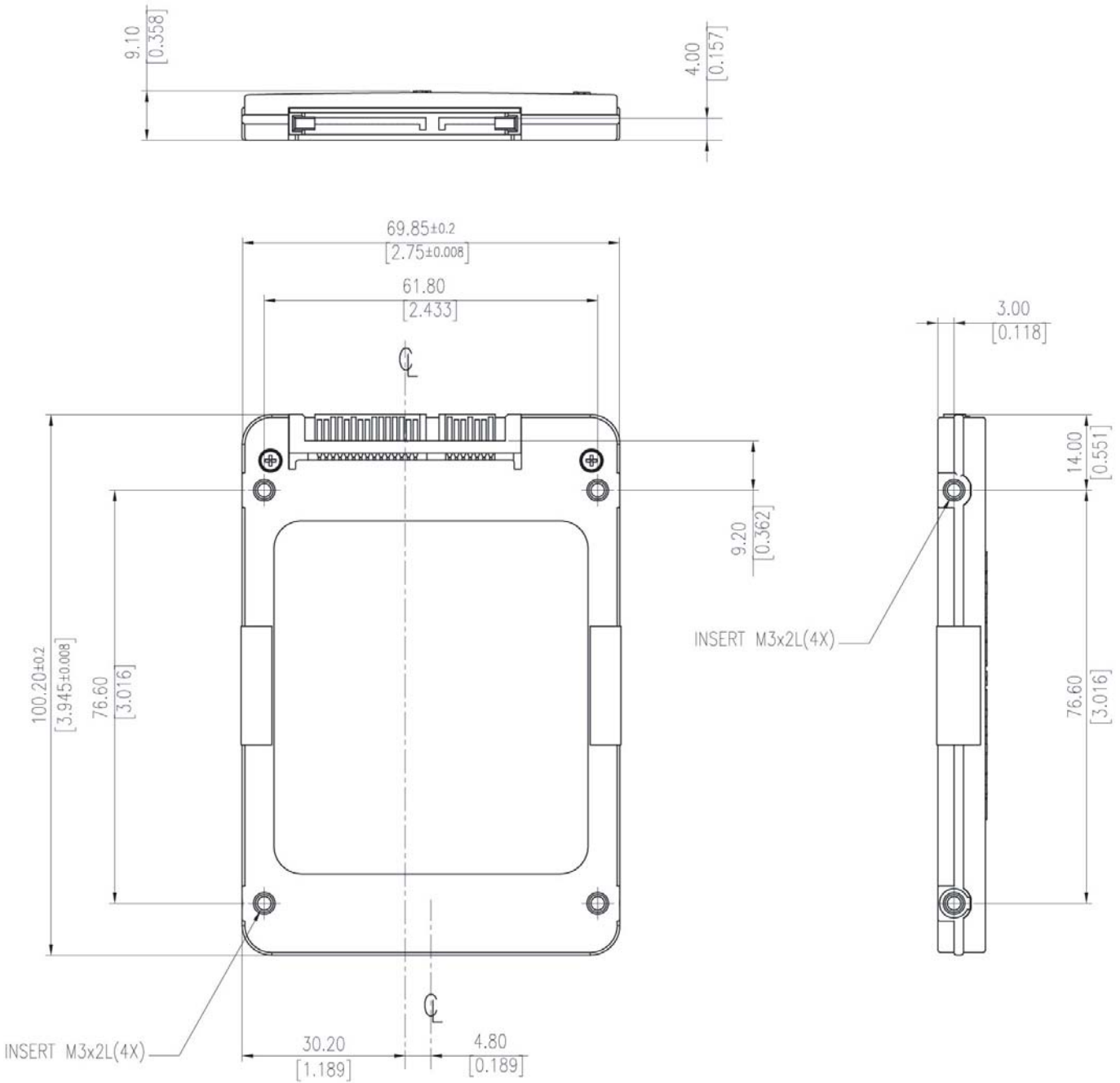

© 2010 Super Talent Technology. Specifications subject to change without notice. US patent # 6,547,130 and others apply. Usable capacity may be less than specified after formatting. Performance is highly dependent upon test environment and use case. Consult our benchmarking data for more detailed performance information or benchmark performance in your environment.