



EPIA-N701

(ARTiGO A2000 Mainboard)

USER'S MANUAL

Version 1.00
December 22, 2008

Copyright

Copyright © 2008 VIA Technologies Incorporated. All rights reserved.

No part of this document may be reproduced, transmitted, transcribed, stored in a retrieval system, or translated into any language, in any form or by any means, electronic, mechanical, magnetic, optical, chemical, manual or otherwise without the prior written permission of VIA Technologies, Incorporated.

Trademarks

All trademarks are the property of their respective holders. PS/2 is a registered trademark of IBM Corporation.

Disclaimer

No license is granted, implied or otherwise, under any patent or patent rights of VIA Technologies. VIA Technologies makes no warranties, implied or otherwise, in regard to this document and to the products described in this document. The information provided in this document is believed to be accurate and reliable as of the publication date of this document. However, VIA Technologies assumes no responsibility for the use or misuse of the information in this document and for any patent infringements that may arise from the use of this document. The information and product specifications within this document are subject to change at any time, without notice and without obligation to notify any person of such change.

FCC-B Radio Frequency Interference Statement

This equipment has been tested and found to comply with the limits for a class B digital device, pursuant to part 15 of the FCC rules. These limits are designed to provide reasonable protection against harmful interference when the equipment is operated in a commercial environment. This equipment generates, uses and can radiate radio frequency energy and, if not installed and used in accordance with the instruction manual, may cause harmful interference to radio communications. Operation of this equipment in a residential area is likely to cause harmful interference, in which case the user will be required to correct the interference at his personal expense.

Notice 1

The changes or modifications not expressly approved by the party responsible for compliance could void the user's authority to operate the equipment.

Notice 2

Shielded interface cables and A.C. power cord, if any, must be used in order to comply with the emission limits.



Tested To Comply
With FCC Standards
FOR HOME OR OFFICE USE

SAFETY INSTRUCTIONS

- Always read the safety instructions carefully.
- Keep this User's Manual for future reference.
- Keep this equipment away from humidity.
- Lay this equipment on a reliable flat surface before setting it up.
- The openings on the enclosure are for air convection hence protects the equipment from overheating. Do not cover the openings.
- Make sure the voltage of the power source and adjust properly 110/220V before connecting the equipment to the power inlet.
- Place the power cord in such a way that people cannot step on it. Do not place anything over the power cord.
- Always unplug the power cord before inserting any add-on card or module.
- All cautions and warnings on the equipment should be noted.
- Never pour any liquid into the opening. Liquid can cause damage or electrical shock.
- If any of the following situations arises, get the equipment checked by a service personnel:
 - The power cord or plug is damaged.
 - Liquid has penetrated into the equipment.
 - The equipment has been exposed to moisture.
 - The equipment has not worked well or you cannot get it work according to User's Manual.
 - The equipment has dropped and damaged.
 - If the equipment has obvious sign of breakage.
- Do not leave this equipment in an environment unconditioned or in a storage temperature above 60°C (140°F). The equipment may be damaged.

**Caution:**

Only use the appropriate battery specified for this product.
Do not reuse, recharge, or reheat an old battery.
Do not attempt to force open the battery.
Do not discard used batteries with regular trash.
Discard used batteries according to local regulations.



TABLE OF CONTENTS

Safety Instructions	iii
Table of Contents	iv
Chapter 1 Specifications	1
Mainboard Specifications	2
Mainboard Layout	4
Back Panel Layout	5
Chapter 2 Installation	7
CPU	8
CPU Fan and System Fan: CPU_FAN and SYS_FAN	8
Memory Module Installation	9
Memory Slot: DDR2 SODIMM SDRAM	9
DDR2 SDRAM Module Installation Procedures	9
Available DDR2 SDRAM Configurations	10
Power Connectors	11
ATX 4-Pin Power Connector: DC 12V	11
External CMOS Battery Connector: BAT1	11
Back Panel Ports	12
RJ-45 Port	12
USB Ports	12
Line-Out	12
Mic/Line-In	12
Connectors	13
SATA Ports	13
VGA Connector: VGA	13
Power Button Connector: PW_BN	14
USB Pin Connector: USB 2/3	14
KB/MS Connector	15
SPI (Serial Peripheral Interface): JSPI	15
LED Connector: JLED	16
LPC Connector: JLPC	17
System Management Bus: SMBus	17
Jumpers	18
Clear CMOS	18
AT/ATX Power	18
Rear Audio Select: JAudio	19
Chapter 3 Daughter Cards	20
NSD7200-A Card Layout	20
Power Cable Connection	21
NSD7200-B Card Layout	22

Power Button Cable Connection.....	23
USB Cable Connection.....	23
LED and Reset Cable Connection.....	24
Chapter 4 BIOS Setup.....	26
Entering the BIOS Setup Menu	27
Control Keys	28
Navigating the BIOS Menus	29
Getting Help.....	30
Main Menu.....	31
Standard CMOS Features	31
Advanced BIOS Features.....	31
Advanced Chipset Features	31
Integrated Peripherals	31
Power Management Setup.....	31
PnP/PCI Configurations.....	31
PC Health Status.....	32
Frequency/Voltage Control	32
Load Optimized Defaults.....	32
Set Supervisor Password.....	32
Set User Password	32
Save & Exit Setup.....	32
Exit Without Saving.....	32
Standard CMOS Features	33
Date	33
Time.....	33
Video.....	33
Halt On.....	33
SATA Drives	34
SATA Channel 0.....	34
SATA Channel 1.....	34
Compact Flash Disk.....	35
Advanced BIOS Features.....	37
Virus Warning.....	37
CPU L1 & L2 Cache	37
CPU L2 Cache ECC Checking.....	37
Quick Power On Self-Test	38
First/Second/Third Boot Device.....	38
Boot Other Device.....	38
Boot Up NumLock Status.....	38
Typematic Rate Setting	38
Typematic Rate (Chars/Sec).....	39
Typematic Delay (Msec).....	39
Security Option.....	39

MPS Version Control for OS.....	39
OS Select for DRAM > 64MB.....	39
HDD S.M.A.R.T Capability.....	39
Video BIOS Shadow.....	39
Full Screen Logo Show.....	39
Summary Screen Show.....	40
CPU Features.....	41
Delay Prior to Thermal.....	41
Thermal Management.....	41
Hard Disk Boot Priority.....	42
Advanced Chipset Features.....	43
Memory Hole.....	43
System BIOS Cacheable.....	43
Video RAM Cacheable.....	43
AGP Fast Write.....	43
Internal VGA Control.....	44
AGP 3.0 Calibration Cycle.....	44
VGA Share Memory Size.....	44
Direct Frame Buffer.....	44
CPU & PCI Bus Control.....	45
PCI Master 0 WS Write.....	45
PCI Delay Transaction.....	45
VIA PWR Management.....	45
Integrated Peripherals.....	46
OnChip IDE Channel 1.....	46
IDE HDD Block Mode.....	46
SATA Controller.....	46
Azalia HDA Controller.....	46
Onboard LAN Boot ROM.....	46
VIA Wireless LAN Support.....	46
Super IO Device.....	47
Internal Serial Port 1.....	47
VIA OnChip IDE Device.....	48
IDE Prefetch Mode.....	48
CF Card UDMA66.....	48
IDE DMA Transfer Access.....	48
Compact Flash PIO.....	48
Compact Flash UDMA.....	48
USB Device Setting.....	49
USB 1.0 Controller.....	49
USB 2.0 Controller.....	49
USB Operation Mode.....	49
USB Keyboard Function.....	49

USB Mouse Function	50
USB Storage Function	50
Power Management Setup	51
ACPI Suspend Type	51
Power Management Option.....	51
HDD Power Down.....	51
Suspend Mode.....	52
Video Off Option.....	52
Video Off Method.....	52
Soft-Off by PWRBTN	52
Run VGABIOS if S3 Resume.....	52
AC Loss Auto Restart.....	52
HPET Support	53
WDRT Support	53
Wakeup Event Detect.....	54
PS2KB Wakeup Select	54
PS2KB Wakeup Key Select	54
PS2MS Wakeup Key Select.....	54
PS2 Keyboard Power On.....	54
PS2 Mouse Power On	55
USB Resume from S3	55
Wakeup On GPI	55
PowerOn by PCI Card.....	55
RTC Alarm Resume.....	55
Date (of Month).....	55
Resume Time (hh : mm : ss).....	55
PnP/PCI Configurations.....	56
PNP OS Installed	56
Reset Configuration Data	56
Resources Controlled By.....	57
PCI/VGA Palette Snoop.....	57
Assign IRQ for VGA.....	57
Assign IRQ for USB.....	57
Maximum Payload Size	57
PC Health Status.....	58
Frequency/Voltage Control	59
DRAM Frequency.....	59
DRAM Channel Mode.....	59
DDR CAS Latency Control	59
DDR Burst Length.....	59
DDR 1T Command Rate.....	59
DRDY Table.....	59
ODT.....	59

Spread Spectrum	60
Load Optimized Defaults	61
Set Supervisor/User Password.....	62
Supervisor Password	62
User Password.....	62
Save & Exit Setup.....	64
Exit Without Saving.....	65
Chapter 5 Driver Installation.....	66
Driver Utilities	67
Getting Started	67
Running the Driver Utilities CD.....	68
CD Content	69

CHAPTER 1

SPECIFICATIONS

The ultra-compact and highly integrated VIA EPIA-N701 uses the Nano-ITX mainboard form-factor developed by VIA Technologies, Inc. as part of the company's open industry-wide total connectivity initiative. The mainboard enables the creation of an exciting new generation of small, ergonomic, innovative and affordable embedded systems. Through a high level of integration, the Nano-ITX occupy 50% of the size of a Mini-ATX mainboard form factor. The mainboard comes with a VIA C7-D Processor, boasting of ultra-low power consumption, cool and quiet operation.

Mainboard Specifications

CPU

- VIA C7-D 1.5GHz processor / 400 MHz FSB

Chipset

- VIA VX800 advanced all-in-one system processor

Graphics

- Integrated VIA Chrome9™ HC3 Integrated Graphics 3D/2D and Unified Video Decoding Accelerator

Audio

- VIA VT1708B High Definition Audio Codec

Memory

- 1 x DDR2 667/533 SODIMM slot (up to 2 GB)

LAN

- 1 x VIA VT6130 PCI Express Gigabit Ethernet Controller

Onboard I/O Connectors

- 2 x SATA port connectors
- 1 x USB pin header for 2 additional USB 2.0 ports
- 1 x CF (CompactFlash) type I connector (shared with IDE)
- 1 x KB/MS pin header
- 1 x SPI pin header
- 1 x Front Panel pin header
- 1 x SMBus pin header (with 5V input)
- 2 x Fan connectors for CPU and System fans
- 1 x Power-on pin header
- 1 x +12V Power input connector
- 1 x MIC-in/Line-in switch header
- 1 x LED indicator pin header
- 1 x Buzzer

Back Panel I/O Ports

- 1 x RJ45 LAN port
- 2 x USB 2.0 ports
- 1 x Audio jack for Line-Out and Mic/Line-In

BIOS

- Award BIOS with SPI 4/8Mbit flash memory capacity

Supported Operating Systems

- Microsoft Windows 2000
- Microsoft Windows XP
- Microsoft Windows CE
- Microsoft Windows XPe
- Linux based operating systems

System Monitoring and Management

- CPU voltage monitoring
- System temperature reading
- Wake-on LAN
- Keyboard Power-On
- Timer Power-On
- Watch Dog Timer
- Fan speed monitor
- System Power management
- AC power failure recovery

Form Factor

- Nano-ITX
- 12cm x 12cm

Mainboard Layout

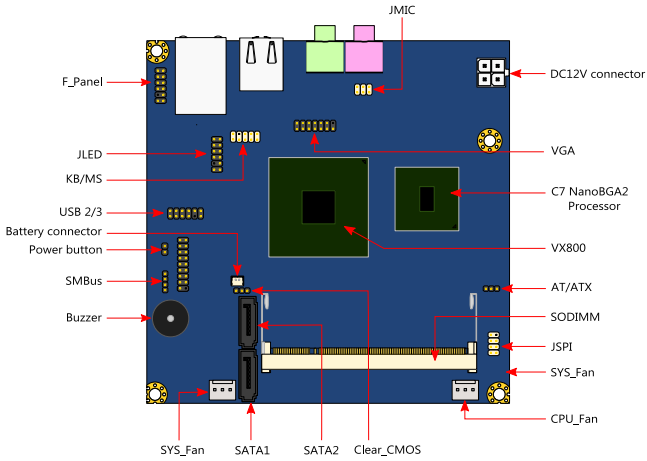

(Top View)

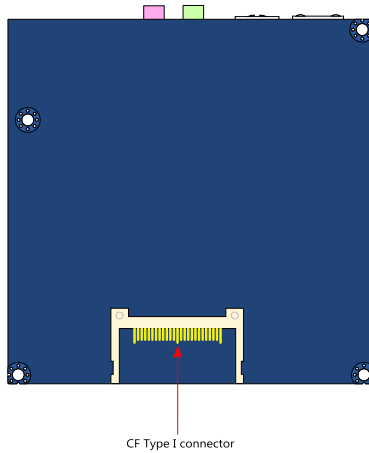

(Bottom View)

Back Panel Layout

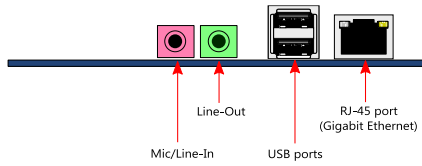

This page is intentionally left blank.

CHAPTER 2

INSTALLATION

This chapter provides you with information about hardware installation procedures. It is recommended to use a grounded wrist strap before handling computer components. Electrostatic discharge (ESD) can damage some components.

CPU

The VIA EPIA-N701 mainboard is packaged with a standard VIA C7-D 1.5 GHz processor. The processor requires a heatsink with fan to provide sufficient cooling.

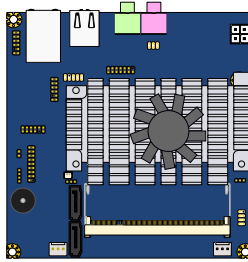

CPU Fan and System Fan: CPU_FAN and SYS_FAN

The CPU_FAN (CPU fan) and SYS_FAN (System fan) run on +12V and maintain system cooling. When connecting the wire to the connectors, always be aware that the red wire (positive wire) should be connected to the +12V. The black wire is Ground and should always be connected to GND.

Pin	Signal
1	SYSFAN_IN
2	+12V
3	GND

Pin	Signal
1	CPUFAN_IN
2	CPUFAN_PWM1
3	GND

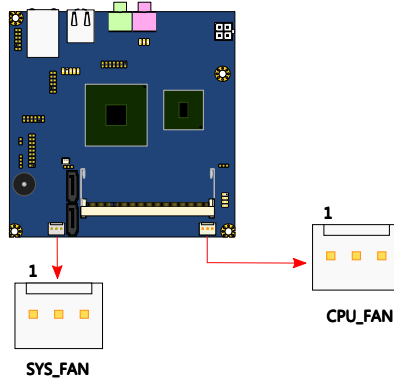

Memory Module Installation

Memory Slot: DDR2 SODIMM SDRAM

The VIA EPIA-N701 mainboard has one 200-pin SODIMM slot for DDR2 667/533 SDRAM memory modules and supports memory sizes up to 2GB.

DDR2 SDRAM Module Installation Procedures

Step 1

Locate the SODIMM slot in the mainboard.

Step 2

Align the notch on the SODIMM with the memory slot.

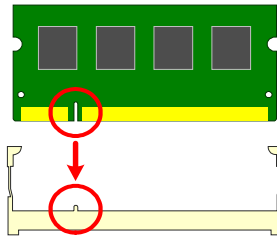

Step 3

Inset the SODIMM module at a 45 degree angle.

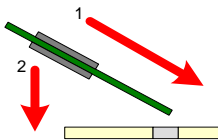

Step 4

Then push the SODIMM down until it snaps into the locking mechanism.

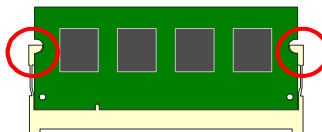

Available DDR2 SDRAM Configurations

Refer to the table below for available DDR2 SDRAM configurations on the mainboard.

Slot	Module Size	Total
SODIMM	64MB, 128MB, 256MB, 512MB, 1GB, 2GB	64MB - 2GB
Maximum supported system memory		2GB

Power Connectors

The VIA EPIA-N701 mainboard supports a 4-pin ATX power connector for the system power input.

ATX 4-Pin Power Connector: DC 12V

To connect the power supply, make sure the power plug is inserted in the proper orientation and the pins are aligned. Then push down the plug firmly into the connector.

Pin	Signal
1	GND
2	GND
3	DC_12V
4	DC_12V

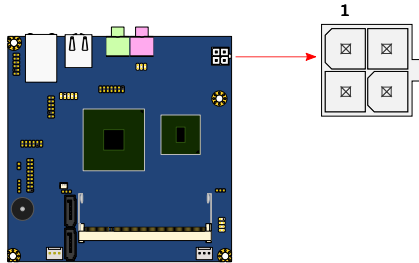

Note:

Before inserting the power supply connector, always make sure that all components are installed correctly to ensure that no damage will be caused.

External CMOS Battery Connector: BAT1

The mainboard comes with external CMOS battery connector. This 2-pin connector used to connect the external cable battery.

Pin	Signal
1	A3V (+3.0V)
2	GND

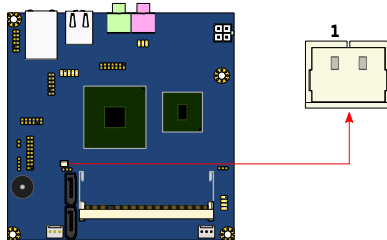

Back Panel Ports

The back panel has the following ports:

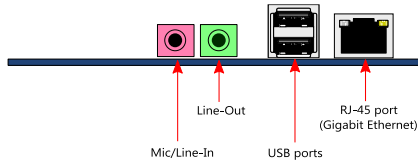

RJ-45 Port

The board provides a standard RJ-45 (Gigabit Ethernet). This port allows the connection to a Local Area Network (LAN) through a network hub.

USB Ports

Two standard USB 2.0 ports are provided on the back panel. These ports are used to connect to USB2.0 devices.

Line-Out

Use for connecting to external speakers or headphones.

Mic/Line-In

Use for connecting to a microphone or Line-in signal.

Connectors

SATA Ports

These next generation connectors support the thin SATA cables for primary internal storage devices. The current SATA interface allows up to 300MB/s data transfer rate, faster than the standard parallel ATA with 133 MB/s (UltraDMA).

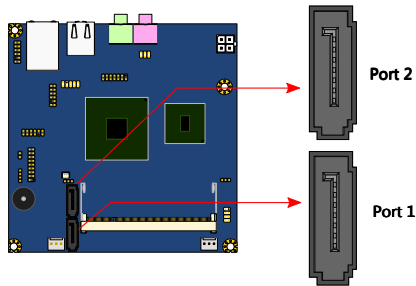

VGA Connector: VGA

This pin header connects to a VGA output cable.

Pin	Signal	Pin	Signal
1	GND	2	+5V
3	CRT_R	4	SPD2
5	CRT_G	6	SPCLK2
7	CRT_B	8	CRT_H2
9	GND	10	CRT_VS
11	GND	12	GND
13	GND	14	Key

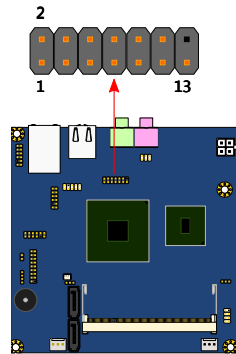

Power Button Connector: PW_BN

This pin header use to connect to the system power button.

Pin	Signal
1	PW_BN
2	GND

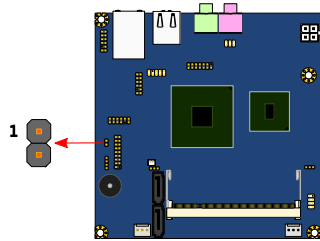

USB Pin Connector: USB 2/3

The mainboard provides one onboard USB pin header that enables up to two additional USB 2.0 ports.

Pin	Signal	Pin	Signal
1	VUSB2	2	VUSB2
3	USBD_T2-	4	USBD_T3-
5	USBD_T2+	6	USBD_T3+
7	GND	8	WLAN_LED
9	Key	10	GND
11	GND	12	GPO36

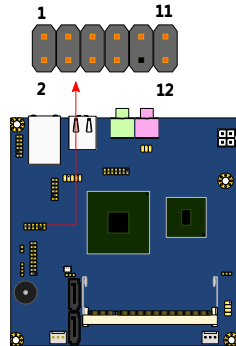

KB/MS Connector

The mainboard provides a PS2 pin header to attach a PS2 keyboard and mouse.

Pin	Signal	Pin	Signal
1	VCCE	2	VCCE
3	NC	4	Key
5	GND	6	GND
7	KB_DT	8	MS_DT
9	KB_CK	10	MS_CK

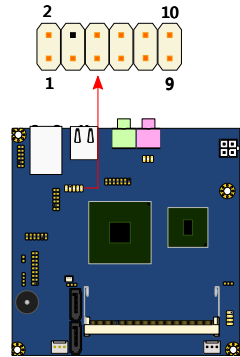

Note:

When the pin header is not in use. Please short pin 3 & 5, pin 4 & 6, pin 7 & 9 and pin 8 & 10.

SPI (Serial Peripheral Interface): JSPI

This pin header is used to connect with SPI BIOS programming fixture.

Pin	Signal	Pin	Signal
1	SPI_VCC	2	GND
3	SPI_SS0	4	SPI_CLK
5	SPI_DI	6	SPI_DO
7	Key	8	RST_SW

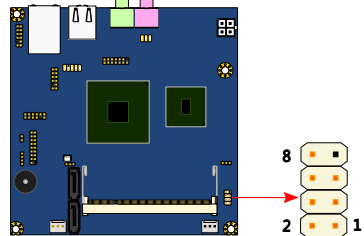

LED Connector: JLED

This pin header is for the LAN active, WLAN active, LAN speed, and HDD active LED indicators on front panel.

Pin	Signal	Pin	Signal
1	RST_SW	2	GND
3	LAN_LED1	4	LAN_VDD33
5	LAN_LED2	6	LAN_ACT
7	GND	8	WLAN_LED
9	Key	10	GND
11	+5V	12	HDD_LED

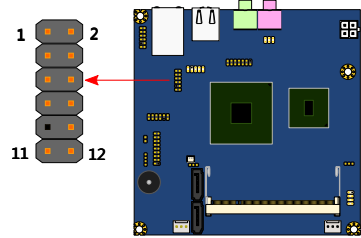

LPC Connector: JLPC

This pin header is for LPC devices.

Pin	Signal	Pin	Signal
1	LPC_AD1	2	SIO_33_CLK
3	-PCI_RST-2	4	GND
5	LPC_AD0	6	SIO_48_CLK
7	LPC_AD2	8	-LPC_FRAME
9	SERIRQ	10	LPC_AD3
11	-LPC_DRQ0	12	EXTSMI
13	+5V	14	+3.3V
15	+5V	16	+3.3V
17	GND	18	GND
19	GND	20	Key

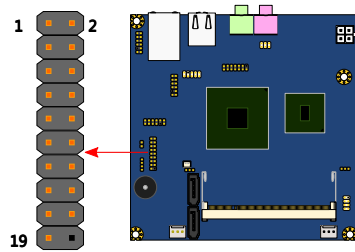

System Management Bus: SMBus

This pin header allows you to connect SMBus (System Management Bus) devices. Devices communicate with a SMBus host and/or other SMBus devices using the SMBus interface.

Pin	Signal
1	SMB_CLK
2	SMB_DAT
3	GND
4	+5V

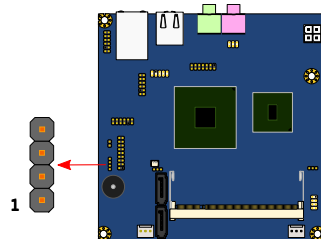

Jumpers

The mainboard provides jumpers for setting some mainboard functions. This section will explain how to change the settings of the mainboard functions using the jumpers.

Clear CMOS

The onboard CMOS RAM stores system configuration data and has an onboard battery power supply. To reset the CMOS settings, set the jumper on pins 1 and 2 while the system is off. Return the jumper to pins 2 and 3 afterwards. Setting the jumper while the system is on will damage the mainboard.

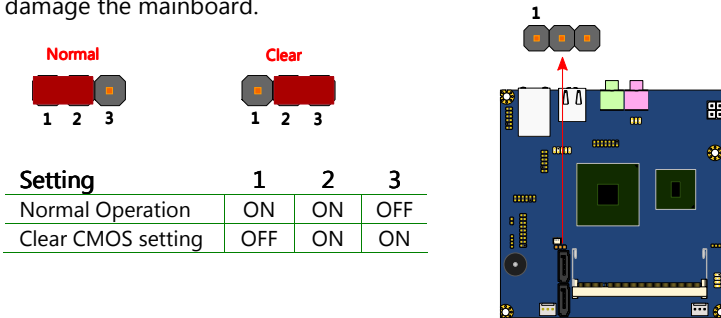

Setting	1	2	3
Normal Operation	ON	ON	OFF
Clear CMOS setting	OFF	ON	ON



Caution:

Except when clearing the RTC RAM, never remove the cap on CLEAR_CMOS jumper default position. Removing the cap will cause system boot failure. Avoid clearing the CMOS while the system is on; it will damage the mainboard.

AT/ATX Power

This pin header is use for AT/ATX power mode select.

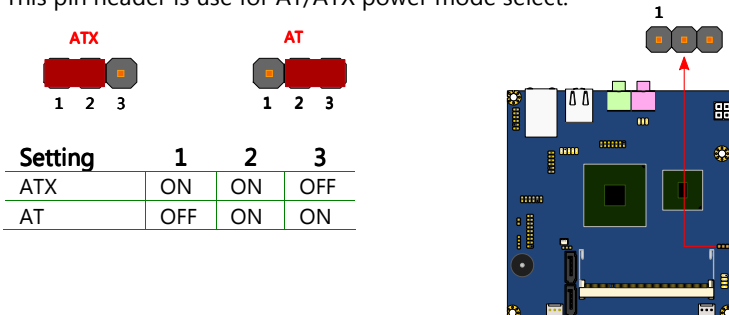

Setting	1	2	3
ATX	ON	ON	OFF
AT	OFF	ON	ON

Rear Audio Select: JAudio

This jumper enables the pink audio jack on the back panel to switch between MIC-in and Line-in.

Setting	Jumper Pairs
MIC-in	1&3, 2&4
Line-in	3&5, 4&6

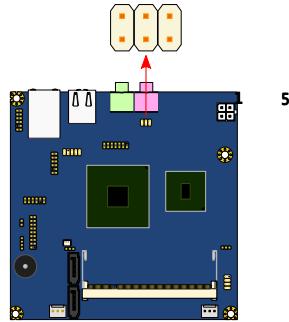

CHAPTER 3

DAUGHTER CARDS

ARTiGO A2000 mainboard EPIA-N701 includes with two daughter cards (NSD7200-A and NSD72000-B) that support the connections to HDD SATA bay connector, front panel USB port, power button, reset button and LED indicators. This chapter shows the proper connections between the daughter cards (NSD72000-A and NSD72000-B) and the EPIA-N701 Nano-ITX mainboard.

NSD7200-A Card Layout

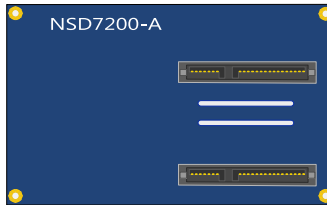

Front View

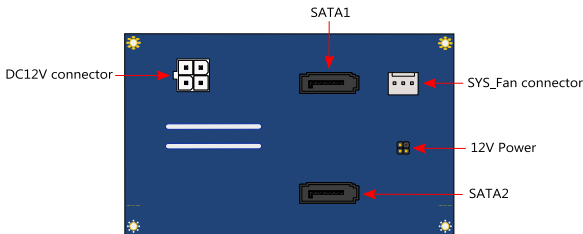

Back View

Power Cable Connection

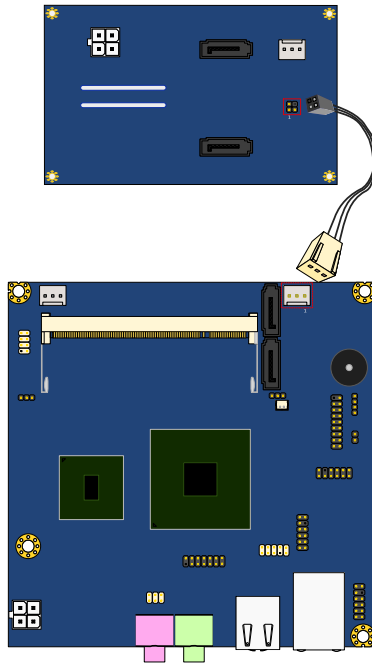

Note:

The power cable for daughter card NSD7200-A must be connected to the SYS_FAN connector of the mainboard.

NSD7200-B Card Layout

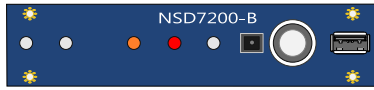

Front View

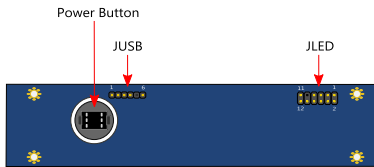

Back View

Power Button Cable Connection

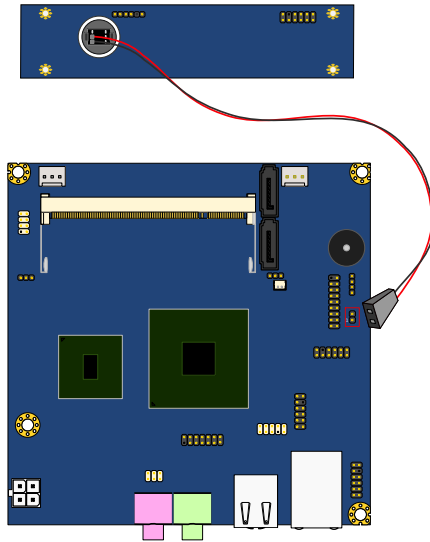

USB Cable Connection

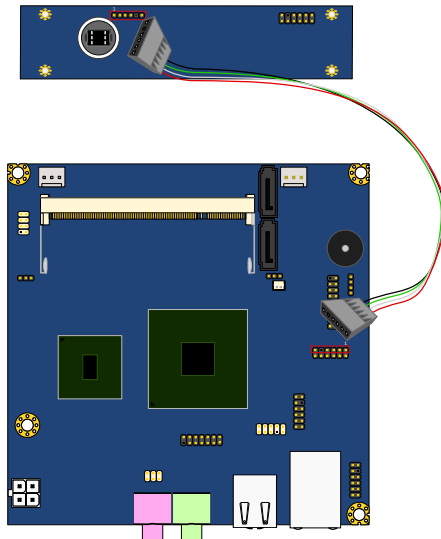

LED and Reset Cable Connection

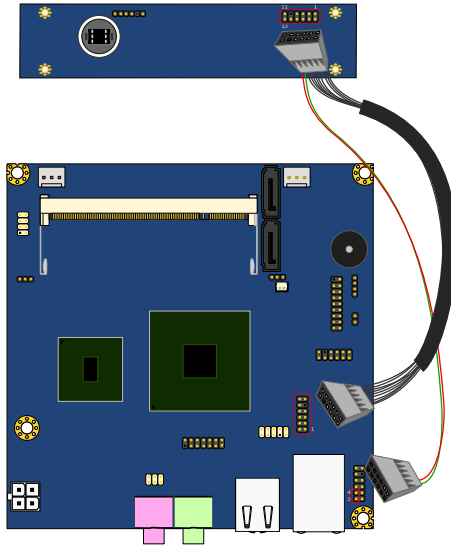

This page is intentionally left blank.

CHAPTER 4













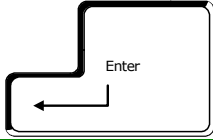

BIOS SETUP

This chapter gives a detailed explanation of the BIOS setup functions.

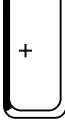
Entering the BIOS Setup Menu

Power on the computer and press <**Delete**> during the beginning of the boot sequence to enter the BIOS setup menu. If you missed the BIOS setup entry point, restart the system and try again.

Control Keys

Keys	Description
	Move to the previous item
	Move to the next item
	Move to the item in the left side
	Move to the item in the right side
	Select the item
	Jumps to the Exit menu or returns to the main menu from a submenu
	Increase the numeric value or make changes
	Decrease the numeric value or make changes
	Increase the numeric value or make changes
	Decrease the numeric value or make changes
	General help, only for Status Page Setup Menu and Option Page Setup Menu
	Restore the previous CMOS value from CMOS, only for Option Page Setup Menu
	Load the default CMOS value from Fail-Safe default table, only for Option Page Setup Menu
	Load Optimized defaults
	Save all the CMOS changes and exit

Navigating the BIOS Menu

The main menu displays all the BIOS setup categories. Use the <Left>/<Right> and <Up>/<Down> arrow keys to select any item or sub-menu. Descriptions of the selected/highlighted category are displayed at the bottom of the screen.

An arrow symbol next to a field indicates that a sub-menu is available (see figure below). Press <Enter> to display the sub-menu. To exit the sub-menu, press <Esc>.

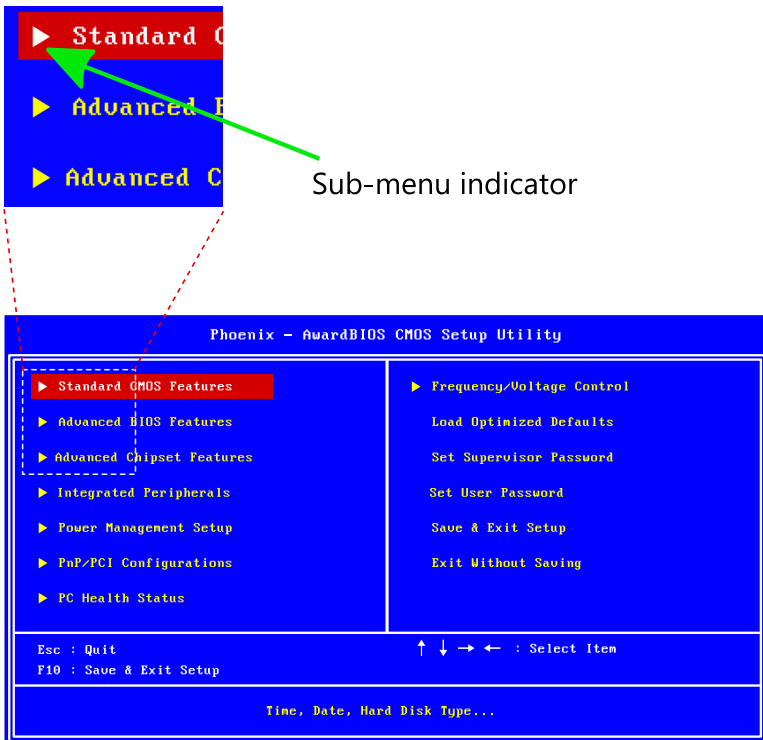

Getting Help

The BIOS setup program provides a "**General Help**" screen. You can display this screen from any menu/sub-menu by pressing <**F1**>. The help screen displays the keys for using and navigating the BIOS setup. Press <**Esc**> to exit the help screen.

Main Menu

The Main Menu contains twelve setup functions and two exit choices. Use arrow keys to select the items and press <Enter> to accept or enter Sub-menu.

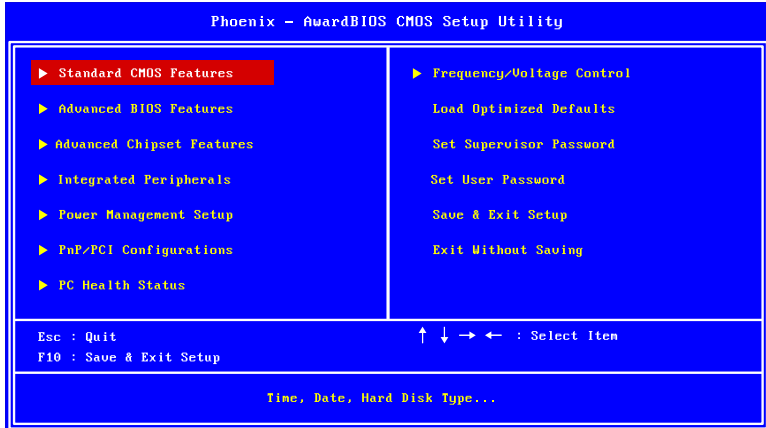

Standard CMOS Features

Use this menu to set basic system configurations.

Advanced BIOS Features

Use this menu to set the advanced features available on your system.

Advanced Chipset Features

Use this menu to set chipset specific features and optimize system performance.

Integrated Peripherals

Use this menu to set onboard peripherals features.

Power Management Setup

Use this menu to set onboard power management functions.

PnP/PCI Configurations

Use this menu to set the PnP and PCI configurations.

PC Health Status

This menu shows the PC health status.

Frequency/Voltage Control

Use this menu to set the system frequency and voltage control.

Load Optimized Defaults

Use this menu option to load BIOS default settings for optimal and high performance system operations.

Set Supervisor Password

Use this menu option to set the BIOS supervisor password.

Set User Password

Use this menu option to set the BIOS user password.

Save & Exit Setup

Save BIOS setting changes and exit setup.

Exit Without Saving

Discard all BIOS setting changes and exit setup.

Standard CMOS Features

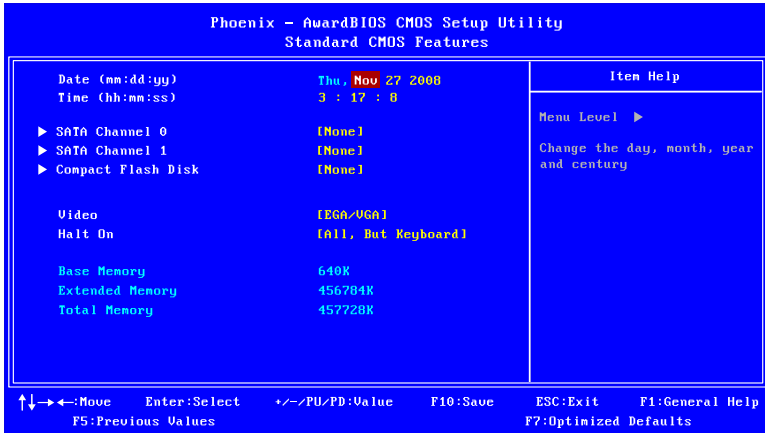

Date

The date format is [Day, Month Date, Year]

Time

The time format is [Hour : Minute : Second]

Video

Settings: [EGA/VGA, CGA 40, CGA 80, MONO]

Halt On

Set the system's response to specific boot errors. Below is a table that details the possible settings.

Settings	Description
All Errors	System halts when any error is detected
No Errors	System does not halt for any error
All, But Keyboard	System halts for all non-key errors

SATA Drives

SATA Channel 0

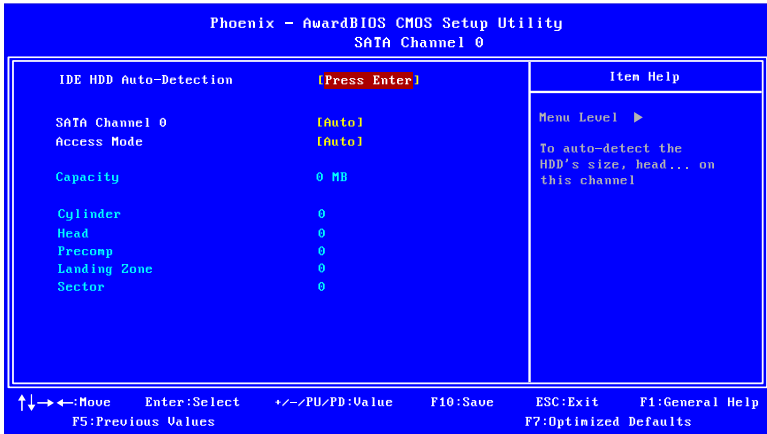

SATA Channel 1

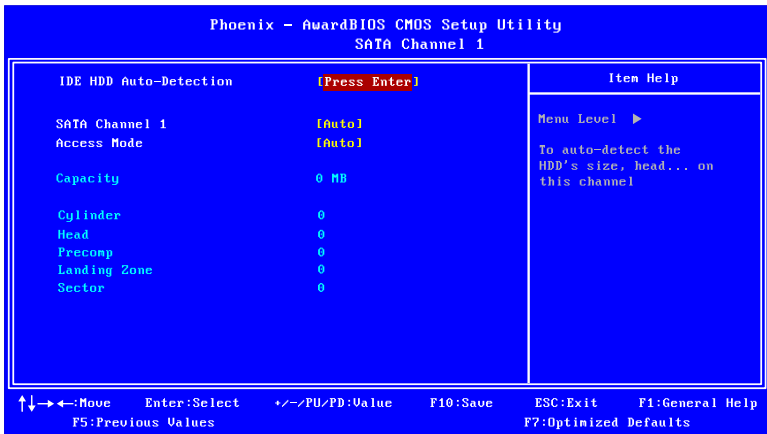

Compact Flash Disk

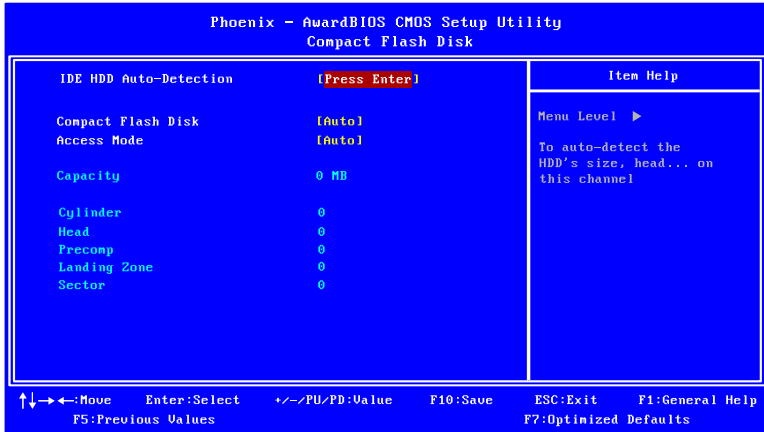

The specifications of your drive must match with the drive table. The hard disk will not work properly if you enter incorrect information in this category. Select **"Auto"** whenever possible. If you select **"Manual"**, make sure the information is from your hard disk vendor or system manufacturer. Below is a table that details required hard drive information when using the **"Manual"** mode.

Settings	Description
SATA Channel	The name of this match the name of the menu. Settings: [None, Auto, Manual]
Compact Flash Disk	Settings: [None, Auto, Manual]
Access Mode	Settings: [CHS, LBA, Large, Auto]
Capacity	Formatted size of the storage device
Cylinder	Number of cylinders
Head	Number of heads
Precomp	Write precompensation
Landing Zone	Cylinder location of the landing zone
Sector	Number of sectors

Advanced BIOS Features

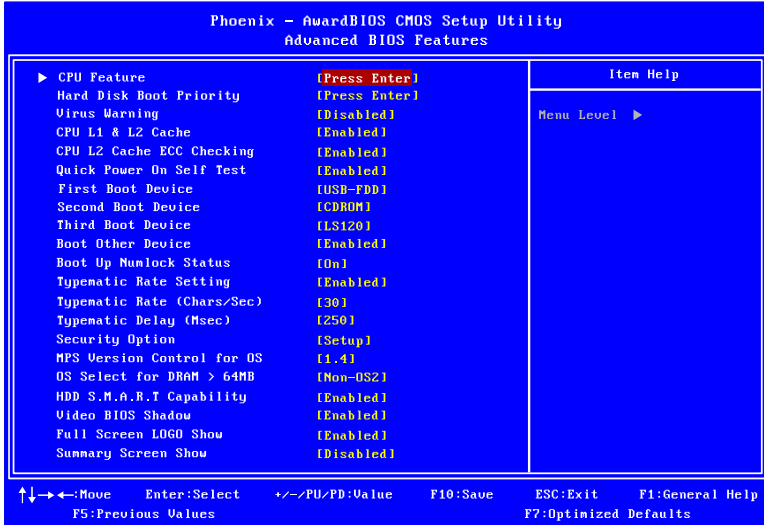

Virus Warning

Allows you to choose the VIRUS warning feature for IDE Hard Disk boot sector protection.

Settings	Description
Enabled	Turns on hard disk boot sector virus protection
Disabled	Turns off hard disk boot sector virus protection



Note:

If this function is enabled and someone attempt to write data into this area, BIOS will show a warning message on the screen and alarm beep.

CPU L1 & L2 Cache

Settings	Description
Disabled	Turns off CPU L1 & L2 cache
Enabled	Turns on CPU L1 & L2 cache

CPU L2 Cache ECC Checking

Settings: [Enabled, Disabled]

Quick Power On Self-Test

Shortens Power On Self-Test (POST) cycle to enable shorter boot up time.

Settings	Description
Disabled	Standard Power On Self Test (POST)
Enabled	Shorten Power On Self Test (POST) cycle and boot up time

First/Second/Third Boot Device

Set the boot device sequence as BIOS attempts to load the disk operating system.

Settings	Description
LS120	Boot from LS-120 drive
Hard Disk	Boot from the HDD
CDROM	Boot from CDROM
ZIP100	Boot from ATAPI ZIP drive
USB-FDD	Boot from USB Floppy drive
USB-ZIP	Boot from USB ZIP drive
USB-CDROM	Boot from USB CDROM
Legacy LAN	Boot from network drive
Disabled	Disable the boot device sequence

Boot Other Device

Enables the system to boot from alternate devices if the system fails to boot from the "First/Second/Third Boot Device" lists.

Settings	Description
Disabled	No alternate boot device allowed
Enabled	Enable alternate boot device

Boot Up NumLock Status

Set the NumLock status when the system is powered on.

Settings	Description
Off	Forces keypad to behave as arrow keys
On	Forces keypad to behave as 10-key

Typematic Rate Setting

Enables "Typematic Rate" and "Typematic Delay" functions.

Settings: [Disabled, Enabled]

Typematic Rate (Chars/Sec)

This item sets the rate (characters/second) at which the system retrieves a signal from a depressed key.

Settings: [6, 8, 10, 12, 15, 20, 24, 30]

Typematic Delay (Msec)

This item sets the delay between, when the key was first pressed and when the system begins to repeat the signal from the depressed key.

Settings: [250, 500, 750, 1000]

Security Option

Selects whether the password is required every time the System boots, or only when you enter Setup.

Settings	Description
Setup	Password prompt appears only when end users try to run BIOS Setup
System	Password prompt appears every time when the computer is powered on and when end users try to run BIOS Setup

MPS Version Control for OS

Settings: [1.1, 1.4]

OS Select for DRAM > 64MB

Select OS2 only if you are running OS/2 operating system with greater than 64MB of RAM on the system.

Settings: [Non-OS2, OS2]

HDD S.M.A.R.T Capability

Settings: [Disabled, Enabled]

Video BIOS Shadow

Enabled copies Video BIOS to shadow RAM Improves performance.

Settings: [Disabled, Enabled]

Full Screen Logo Show

Show full screen logo during BIOS boot up process.

Settings: [Disabled, Enabled]

Summary Screen Show

Show summary screen.

Settings: [Disabled, Enabled]

CPU Features

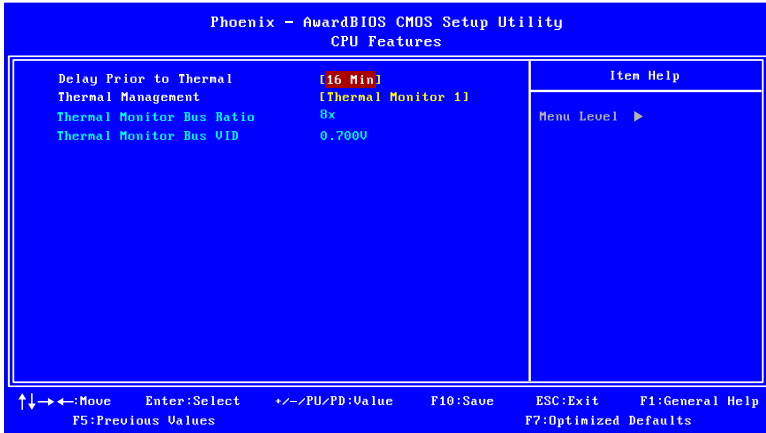

Delay Prior to Thermal

Settings: [4 Min, 8 Min, 16 Min, 32 Min]

Thermal Management

This item sets CPU's thermal control rule to protect CPU from overheat.

Settings	Description
Thermal Monitor 1	On-die throttling
Thermal Monitor 2	Ratio & VID transition

Hard Disk Boot Priority

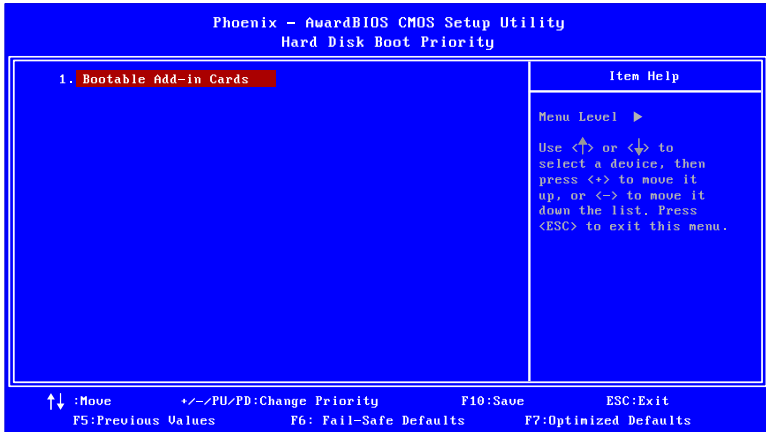

This is for setting the priority of the hard disk boot order when the "Hard Disk" option is selected in the "[First/Second/Third] Boot Device" menu item.

Advanced Chipset Features

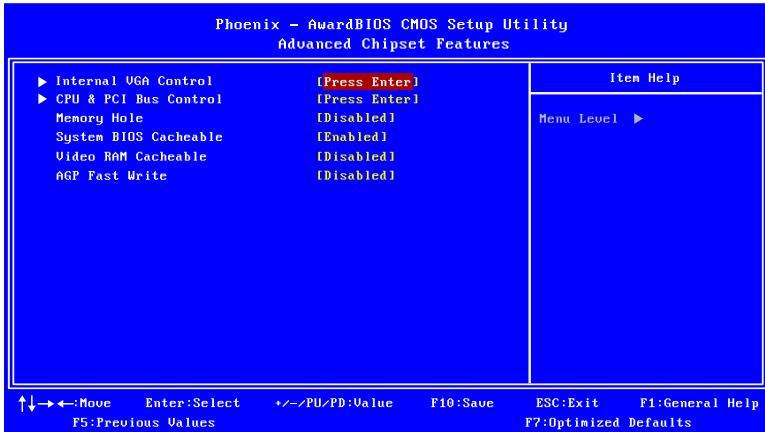

Caution:
The Advanced Chipset Features menu is used for optimizing the chipset functions. Do not change these settings unless you are familiar with the chipset.

Memory Hole

Settings: [Disabled, 15M – 16M]

System BIOS Cacheable

Settings: [Disabled, Enabled]

Video RAM Cacheable

Settings: [Disabled, Enabled]

AGP Fast Write

Settings: [Disabled, Enabled]

Internal VGA Control

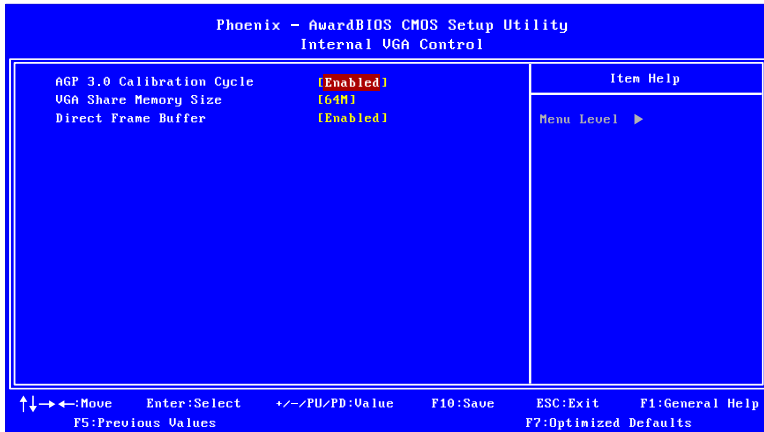

AGP 3.0 Calibration Cycle

Settings: [Disabled, Enabled]

VGA Share Memory Size

This setting allows you to select the amount of system memory that is allocated to the integrated graphics processor.

Settings: [Disabled, 64M, 128M, 256M]

Direct Frame Buffer

Settings: [Disabled, Enabled]

CPU & PCI Bus Control

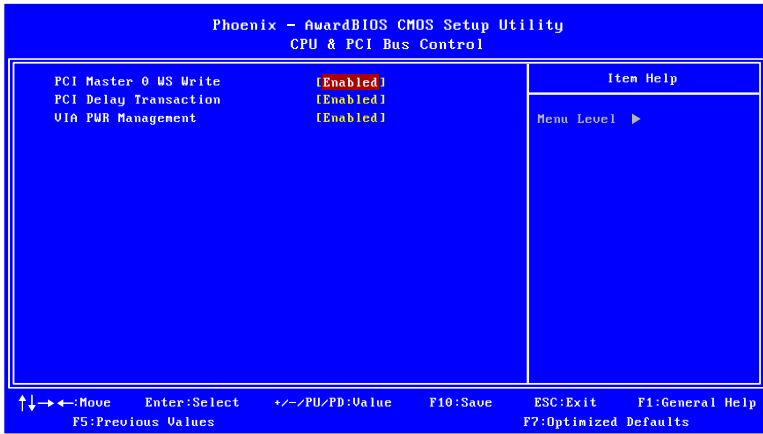

PCI Master 0 WS Write

Settings: [Enabled, Disabled]

PCI Delay Transaction

Settings: [Disabled, Enabled]

VIA PWR Management

Settings: [Disabled, Enabled]

Integrated Peripherals

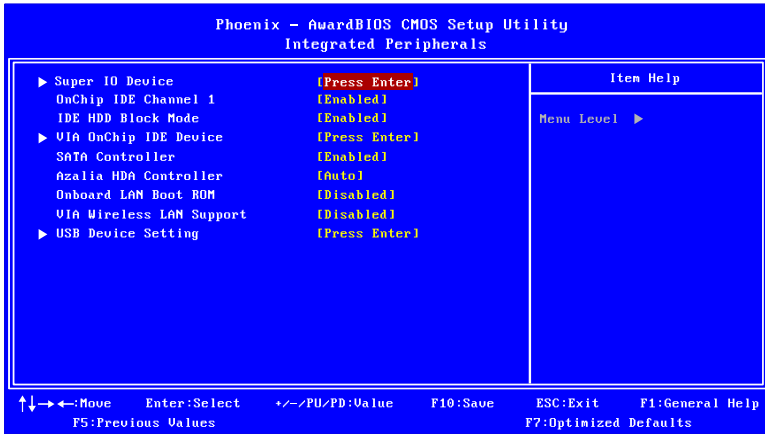

OnChip IDE Channel 1

Settings: [Disabled, Enabled]

IDE HDD Block Mode

Settings: [Disabled, Enabled]

SATA Controller

Settings: [Disabled, Enabled]

Azalia HDA Controller

Settings: [Auto, Disabled]

Onboard LAN Boot ROM

Settings: [Enabled, Disabled]

VIA Wireless LAN Support

Settings: [Enabled, Disabled]

Super IO Device

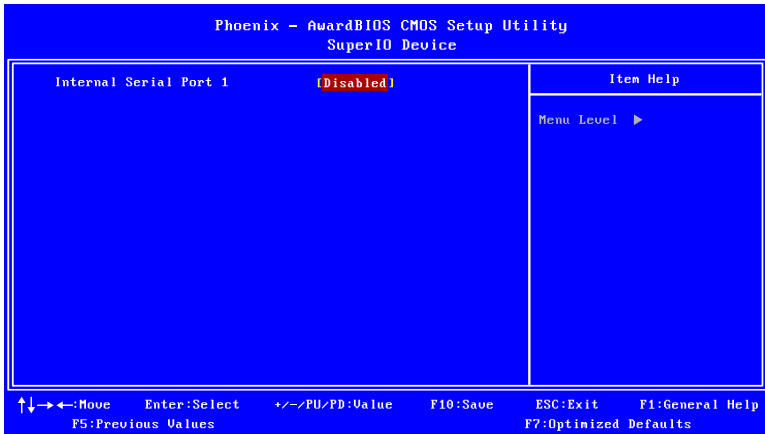

Internal Serial Port 1

Settings: [Disabled, 3F8/IRQ4, 2F8/IRQ3, 3E8/IRQ4, 2E8/IRQ3]

VIA OnChip IDE Device

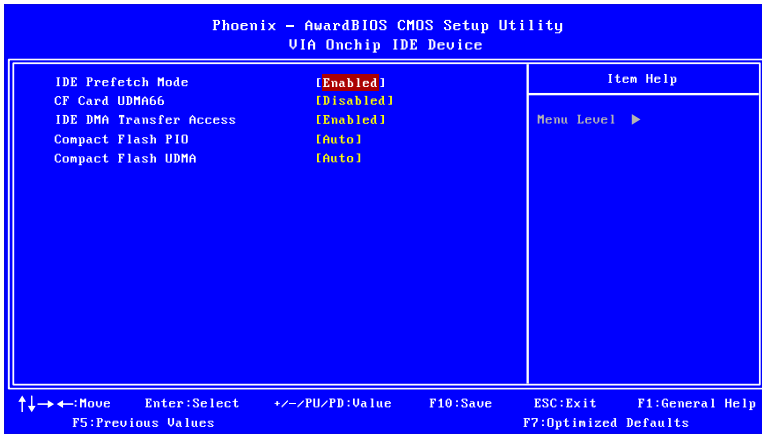

IDE Prefetch Mode

Settings: [Disabled, Enabled]

CF Card UDMA66

Settings: [Disabled, Enabled]

IDE DMA Transfer Access

Settings: [Disabled, Enabled]

Compact Flash PIO

Settings: [Auto, Mode 0, Mode 1, Mode 2, Mode 3, Mode 4]

Compact Flash UDMA

Settings: [Disabled, Auto]

USB Device Setting

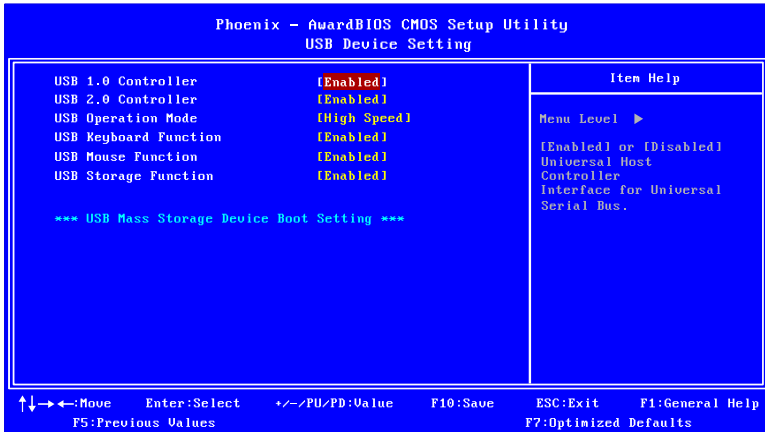

USB 1.0 Controller

Enable or disable Universal Host Controller Interface for Universal Serial Bus.

Settings: [Disabled, Enabled]

USB 2.0 Controller

Enable or disable Enhanced Host Controller Interface for Universal Serial Bus.

Settings: [Disabled, Enabled]

USB Operation Mode

Auto decide USB device operation mode.

Settings	Description
Full/Low Speed	All of USB Device operated on full/low speed mode
High Speed	If USB device was high speed device, then it operated on high speed mode.

USB Keyboard Function

Enable or disable Legacy support of USB Keyboard.

Settings: [Disabled, Enabled]

USB Mouse Function

Settings: [Disabled, Enabled]

USB Storage Function

Enable or disable Legacy support of USB Mass Storage.

Settings: [Disabled, Enabled]

Power Management Setup

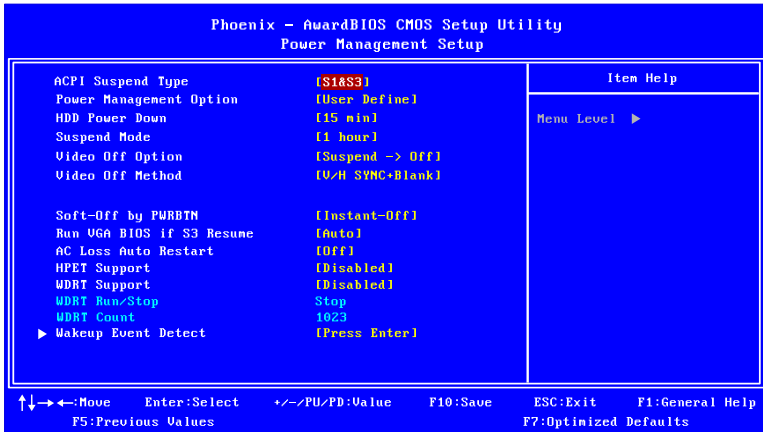

ACPI Suspend Type

Settings	Description
S1(POS)	S1/Power On Suspend (POS) is a low power state. In this state, no system context (CPU or chipset) is lost and hardware maintains all system contexts.
S3(STR)	S3/Suspend To RAM (STR) is a power-down state. In this state, power is supplied only to essential components such as main memory and wakeup-capable devices. The system context is saved to main memory, and context is restored from the memory when a "wakeup" event occurs.
S1 & S3	Depends on the OS to select S1 or S3.

Power Management Option

Settings: [User Define, Min Saving, Max Saving]

HDD Power Down

Set the length of time for a period of inactivity before powering down the hard disk.

Settings: [Disable, 1 Min, 2 Min, 3 Min, 4 Min, 5 Min, 6 Min, 7 Min, 8 Min, 9 Min, 10 Min, 11 Min, 12 Min, 13 Min, 14 Min, 15 Min]

Suspend Mode

Sets the length of time for a period of inactivity before entering suspend mode.

Settings: [Disable, 1 Min, 2 Min, 4 Min, 6 Min, 8 Min, 10 Min, 20 Min, 30 Min, 40 Min, 1 Hour]

Video Off Option

Select whether or not to turn off the screen when system enters power saving mode, ACPI OS such as Windows XP will override this option.

Settings	Description
Always On	Screen is always on even when system enters power saving mode
Suspend -> Off	Screen is turned off when system enters power saving mode

Video Off Method

Settings: [Blank Screen, V/H SYNC+Blank, DPMS Support]

Soft-Off by PWRBTN

This field configures the power button on the chassis.

Settings	Description
Delay 4 Sec	System is turned off if power button is pressed for more than four seconds.
Instant-Off	Power button functions as a normal power-on/-off button.

Run VGABIOS if S3 Resume

Select whether to run VGA BIOS if resuming from S3 state. This is only necessary for older VGA drivers.

Settings: [Auto, Yes, No]

AC Loss Auto Restart

The field defines how the system will respond after an AC power loss during system operation.

Settings	Description
Off	Keeps the system in an off state until the power button is pressed
On	Restarts the system when the power is back
Former-Sts	Former-Sts

HPET Support

Settings: [Disabled, Enabled]

WDRT Support

Settings: [Disabled, Enabled]

Wakeup Event Detect

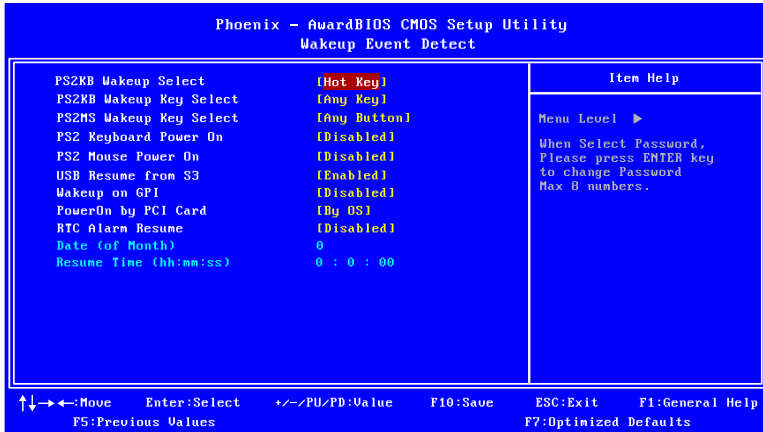

PS2KB Wakeup Select

When selecting "Password", press <Page Up> or <Page Down> to change password. The maximum number of characters is eight. "PS2MS Wakeup from S3/S4/S5" and "PS2KB Wakeup from S3/S4/S5" will be disabled while changing the password.

Settings: [Hot Key, Password]

PS2KB Wakeup Key Select

Sets a Hot Key to restore the system from the power saving mode to an active state.

Settings: [Ctrl+F1, Ctrl+F2, Ctrl+F3, Ctrl+F4, Ctrl+F5, Ctrl+F6, Ctrl+F7, Ctrl+F8, Ctrl+F9, Ctrl+F10, Ctrl+F11, Ctrl+F12, Power, Wake, Any Key]

PS2MS Wakeup Key Select

Enables any mouse activity to restore the system from the power saving mode to an active state.

Settings: [Any Button, Left Button, Right Button]

PS2 Keyboard Power On

Settings: [Disabled, Enabled]

PS2 Mouse Power On

Settings: [Disabled, Enabled]

USB Resume from S3

Settings: [Disabled, Enabled]

Wakeup On GPI

Settings: [Disabled, Enabled]

PowerOn by PCI Card

Enables activity detected from any PCI card to power up the system or resume from a suspended state. Such PCI cards include LAN, onboard USB ports, etc.

Settings: [By OS, Enabled]

RTC Alarm Resume

Set a scheduled time and/or date to automatically power on the system.

Settings: [Disabled, Enabled]

Date (of Month)

The field specifies the date for "RTC Alarm Resume".

Key in a DEC number.

Settings: [Min = 0, Max = 31]

Resume Time (hh : mm : ss)

The field specifies the time for "RTC Alarm Resume".

Key in a DEC number.

Settings: [Min = 0, Max = 23]

PnP/PCI Configurations

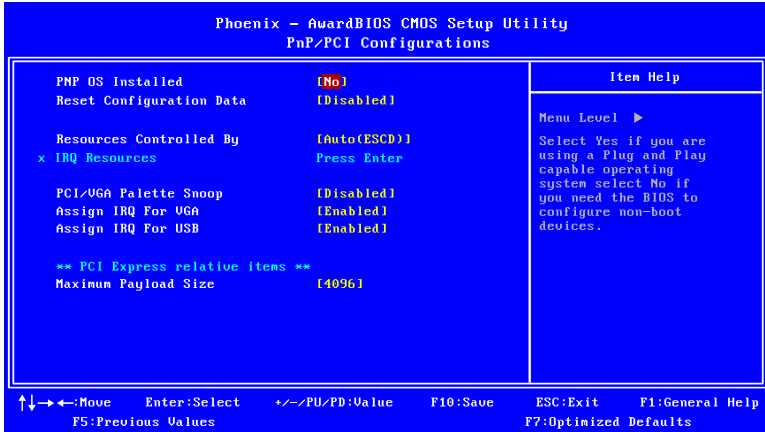

Note: This section covers some very technical items and it is strongly recommended to leave the default settings as is unless you are an experienced user.

PNP OS Installed

Settings	Description
No	BIOS will initialize all the PnP cards
Yes	BIOS will only initialize the PnP cards used for booting (VGA, IDE, SCSI). The rest of the cards will be initialized by the PnP operating system

Reset Configuration Data

Settings	Description
Disabled	Default setting
Enabled	Resets the ESCD (Extended System Configuration Data) after exiting BIOS Setup if a newly installed PCI card or the system configuration prevents the operating system from loading

Resources Controlled By

Enable the BIOS to automatically configure all the Plug-and-Play compatible devices.

Settings	Description
Auto(ESCD)	BIOS will automatically assign IRQ, DMA and memory base address fields
Manual	Unlocks "IRQ Resources" for manual configuration

PCI/VGA Palette Snoop

Some non-standard VGA display cards may not show colors properly. This field allows you to set whether MPEG ISA/VESA VGA Cards can work with PCI/VGA or not. When enabled, a PCI/VGA can work with a MPEG ISA/VESA VGA card. When disabled, a PCI/VGA cannot work with a MPEG ISA/VESA Card.

Settings: [Disabled, Enabled]

Assign IRQ for VGA

Assign IRQ for VGA devices.

Settings: [Disabled, Enabled]

Assign IRQ for USB

Assign IRQ for USB devices.

Settings: [Disabled, Enabled]

Maximum Payload Size

Set maximum TLP payload size for the PCI Express devices. The unit is byte.

Settings: [128, 256, 512, 1024, 2048, 4096]

PC Health Status

Phoenix - AwardBIOS CMOS Setup Utility		Item Help
PC Health Status		
System Temperature	22°C/71°F	
CPU FAN Speed	4687 RPM	
System FAN Speed	0 RPM	
UCORE	1.07V	Menu Level ▶
+1.8V	1.80V	
+3.3V	3.3V	
+VCCP	1.00V	
+5V	4.95V	

↑↓←→ Move Enter:Select +/-/PU/PD:Value F10:Save ESC:Exit F1:General Help
 F5:Previous Values F7:Optimized Defaults

The PC Health Status displays the current status of all of the monitored hardware devices/components such as CPU voltages, temperatures and fan speeds.

Frequency/Voltage Control

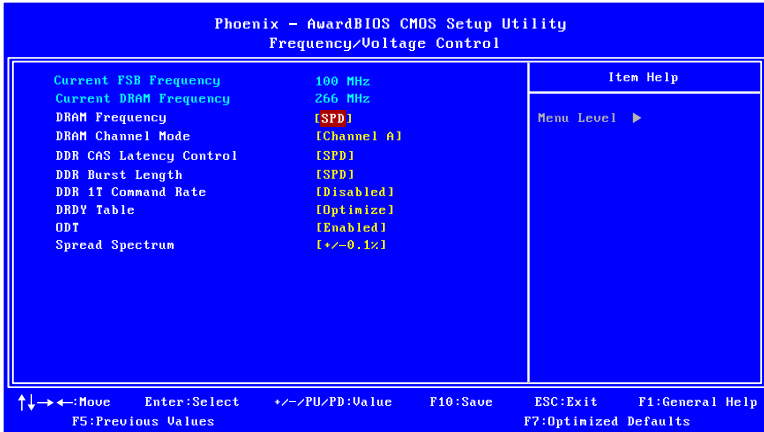

DRAM Frequency

Settings: [DDR2-400, DDR2-533, DDR-667, SPD]

DRAM Channel Mode

Settings: [Channel A, Channel A&B, Channel A&C]

DDR CAS Latency Control

Settings: [2T, 3T, 4T, 5T, 6T, SPD]

DDR Burst Length

Settings: [4, 8, SPD]

DDR 1T Command Rate

Settings: [Disabled, Enabled]

DRDY Table

Settings: [Slowest, Optimize]

ODT

Settings: [Disabled, Enabled]

Spread Spectrum

When the mainboard's clock generator pulses, the extreme values (spikes) of the pulses create EMI (Electromagnetic Interference). The Spread Spectrum function reduces the EMI generated by modulating the pulses so that the spikes of the pulses are reduced to flatter curves.

Settings: [Disabled, +/- 0.1%, +/- 0.2%, +/- 0.3%, +/- 0.4%, +/- 0.5%, +/- 0.6%, +/- 0.7%, +/- 0.8%, +/- 0.9%]

Load Optimized Defaults

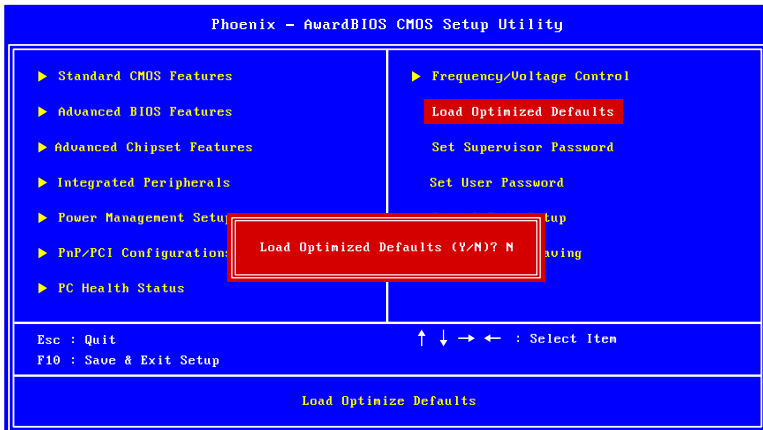

This option is for restoring all the default optimized BIOS settings. The default optimized values are set by the mainboard manufacturer to provide a stable system with optimized performance.

Entering "Y" and press <Enter> to load the default optimized BIOS values. Entering "N" will cancel the load optimized defaults request.

Set Supervisor/User Password

Supervisor Password

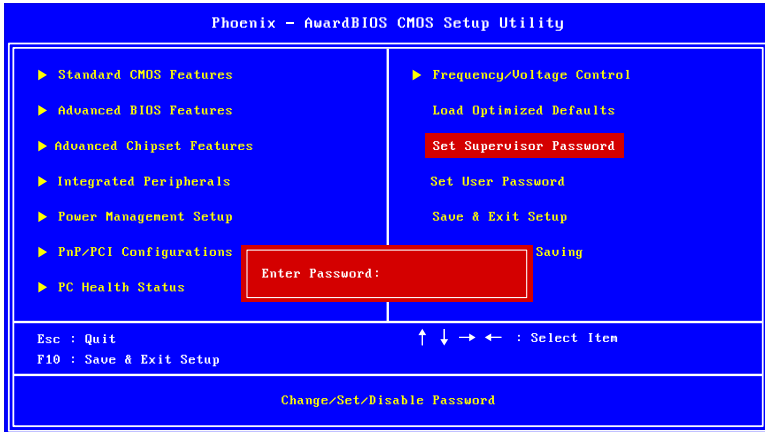

User Password

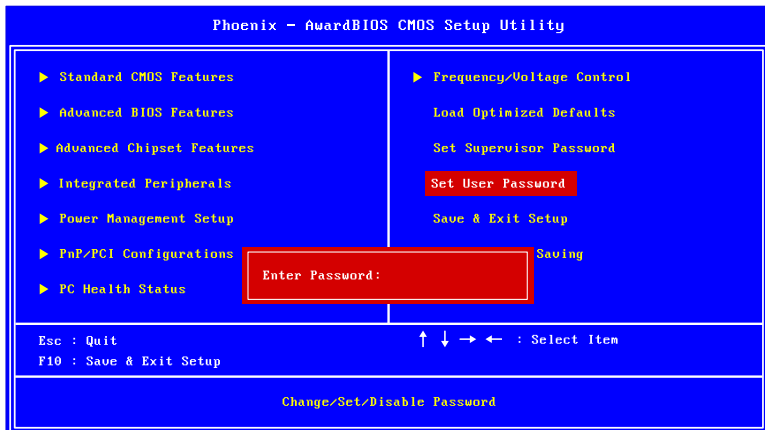

This option is for setting a password for entering BIOS Setup. When a password has been set, a password prompt will be displayed whenever BIOS Setup is run. This prevents an unauthorized person from changing any part of your system configuration.

There are two types of passwords you can set. A supervisor password and a user password. When a supervisor password is used, the BIOS Setup program can be accessed and the BIOS settings can be changed. When a user password is used, the BIOS Setup program can be accessed but the BIOS settings cannot be changed.

To set the password, type the password (up to eight characters in length) and press <Enter>. The password typed now will clear any previously set password from CMOS memory. The new password will need to be reentered to be confirmed. To cancel the process press <Esc>.

To disable the password, press <Enter> when prompted to enter a new password. A message will show up to confirm disabling the password. To cancel the process press <Esc>.

Additionally, when a password is enabled, the BIOS can be set to request the password each time the system is booted. This would prevent unauthorized use of the system. See "Security Option" in the "Advanced BIOS Features" section for more details.

Save & Exit Setup

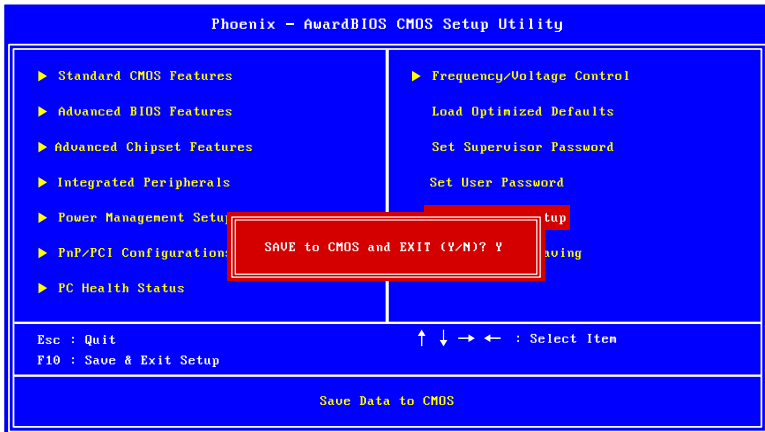

Entering "Y" saves any changes made, and exits the program.
Entering "N" will cancel the exit request.

Exit Without Saving

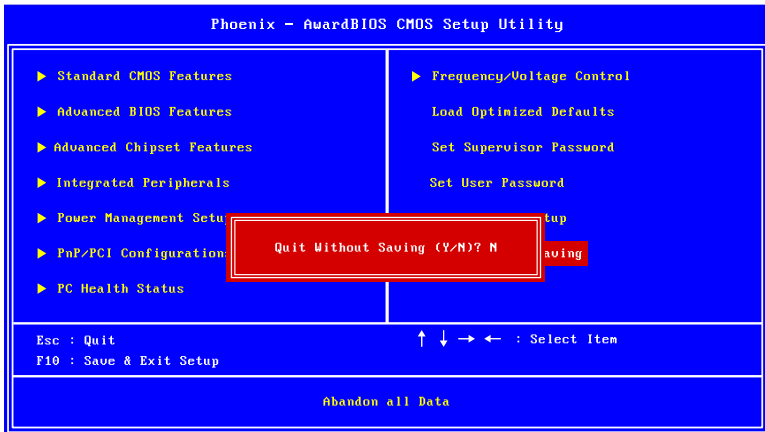

Entering "Y" discards any changes made and exits the program.
Entering "N" will cancel the exit request.

CHAPTER 5

DRIVER INSTALLATION

This chapter gives you brief descriptions of each mainboard driver and application. You must install the VIA chipset drivers first before installing other drivers such as VGA drivers. The applications will only function correctly if the necessary drivers are already installed.

Driver Utilities

Getting Started

The mainboard includes a Driver Utilities CD that contains the drivers and software for enhancing the performance of the mainboard. If the CD is missing from the retail box, please contact the local dealer for the CD.



Note:

The driver utilities and software are updated from time to time. The latest updated versions are available at <http://www.viaembedded.com/>.

Running the Driver Utilities CD

To start using the CD, insert the CD into the CD-ROM or DVD-ROM drive. The CD should run automatically after closing the CD-ROM or DVD-ROM drive. The driver utilities and software menu screen should then appear on the screen. If the CD does not run automatically, click on the "Start" button and select "Run..." Then type: "D:\Setup.exe".

For Linux drivers, click the right button on mouse and click open. Linux drivers are located in the "Driver" folder.



Note:

D: might not be the drive letter of the CD-ROM/DVD-ROM in your system.

CD Content

- **VIA 4in1 Drivers:**
 - Contains VIA ATAPI Vendor Support Driver (enables the performance enhancing bus mastering functions on ATA-capable Hard Disk Drives and ensures IDE device compatibility), AGP VxD Driver (provides service routines to your VGA driver and interface directly to hardware, providing fast graphical access), IRQ Routing Miniport Driver (sets the system's PCI IRQ routing sequence) and VIA INF Driver (enables the VIA Power Management function).

- **VIA Graphics Driver:**
 - Enhances the onboard VIA graphic chip.

- **VIA Audio Driver:**
 - Enhances the onboard VIA audio chip.

- **VIA USB 2.0 Driver:**
 - Enhances VIA USB 2.0 ports.

- **VIA LAN Driver:**
 - Enhances the onboard VIA VT6130 PCIe Gigabit Ethernet chip.