



# LEADTEK GPS MODULE GPS LR9102 Specifications Sheet



*Features:*

- SiRF GSC3f/LP single chipset
- Compact module size for easy integration : 15 x 14 x 2.8 mm
- RoHS compliance



ALL INFORMATION CONTAINED HEREIN IS THE SOLE PROPERTY OF LEADTEK RESEARCH AND CANNOT BE DISSEMINATED WITHOUT THE EXPRESS WRITTEN CONSENT OF LEADTEK RESEARCH.

## 1. Introduction

The Leadtek GPS 9102 module (LR9102) is a high sensitivity, low power and very compact Surface Mount Device (SMD). This 20-channel global positioning system (GPS) receiver is designed for a broad spectrum of OEM applications and is based on the fast and deep GPS signal search capabilities of SiRFStarIII™ GSC3f/LP low power single chipset architecture. Leadtek GPS 9102 is designed to allow quick and easy integration into GPS-related applications, especially for compact size devices, such as:

- PDA, Pocket PC, PND and other computing devices (Ex. UMPC)
- Fleet Management / Asset Tracking
- AVL application and Location-Based Services (LBS)
- Hand-held Device for Personal Positioning and Navigation

### 1.1. Features

#### Hardware and Software

- Based on the high performance features of the SiRF GSC3f/LP low power single chipset.
- Compact module size for easy integration: 15 x 14 x 2.8 mm (0.59 x 0.55 x 0.11 in).
- SMT pads allow for fully automatic assembly processes equipment and reflow soldering
- RoHS compliant (lead-free)

#### Performance

- Cold/Warm/Hot Start Time: 42 / 35 / 1 sec.
- Reacquisition Time: 0.1 second
- RF Metal Shield for best performance in noisy environments
- Multi-path Mitigation Hardware

### Interface

- TTL level serial port for GPS communications interface
- Protocol: NMEA-0183/SiRF Binary (default NMEA)
- Baud Rate: 4800 ~ 19200 bps (default 9600)

### 1.2. Advantages

- Ideal for compact size devices
- Data / Power / RF through surface mount pads
- Cost saving through elimination of RF and board to board digital connectors
- Flexible and cost effective hardware design for different application requirements
- Secure SMD PCB mounting method

## 2. Technical specifications

### 2.1. Module architecture

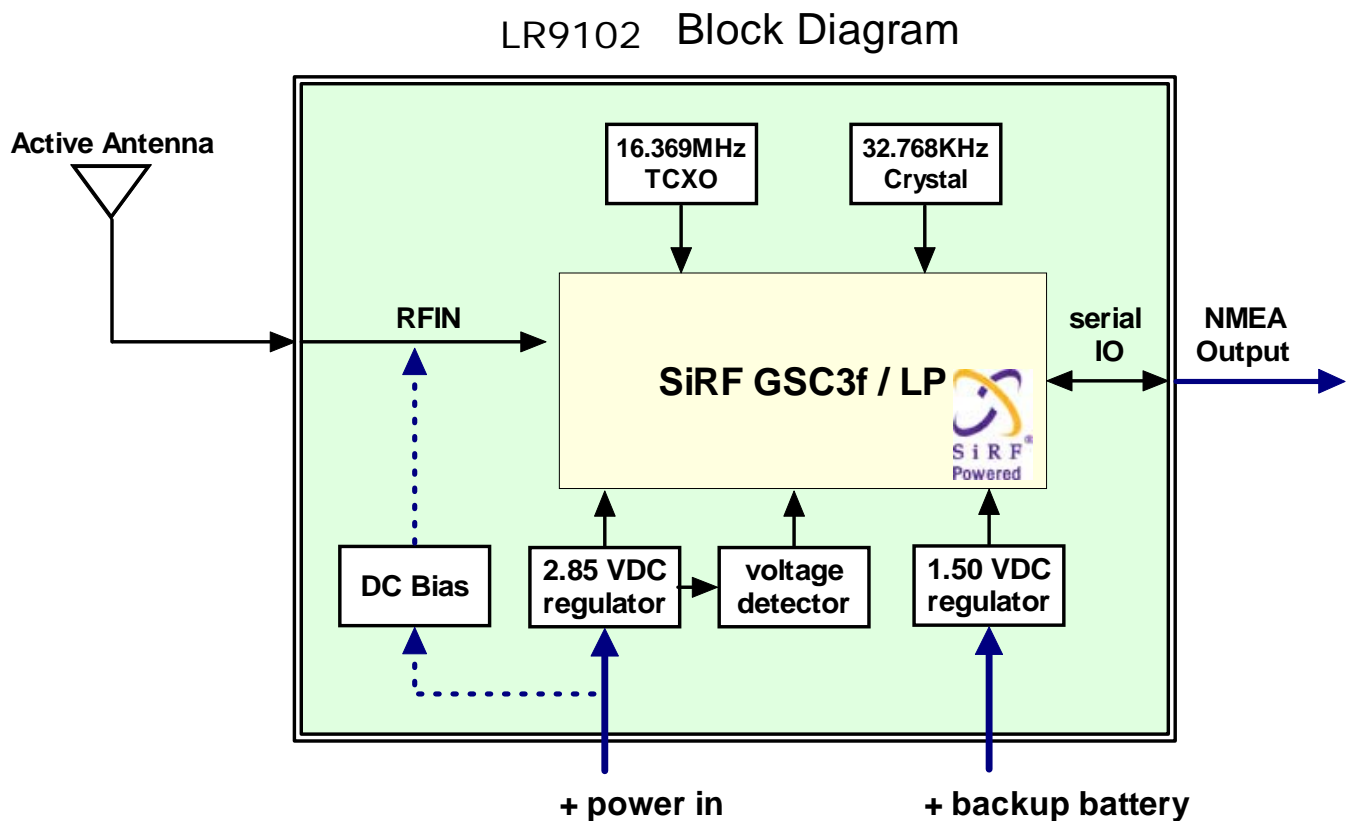

## Hardware Features

- Based on the high performance features of the SiRF GSC3f/LP low power single chipset
- Compact module size for easy integration: 15 x 14 x 2.8 mm (0.59 x 0.55 x 0.11 in).
- SMT pads allow for fully automatic assembly processes equipment and reflow soldering
- RoHS compliant (lead-free)

## 2.2. Software Features

The firmware used on Leadtek 9102 module is GSW3.2.4, the software for SiRF StarIII low power single chipset receivers, and the default configuration is as following description:

Item	Description
Core of firmware	SiRF GSW3.2.4
Baud rate	4800 ~ 19200 bps (default 9600)
Code type	NMEA-0183 ASCII
Datum	WGS-84
Protocol message	GGA, GSA, GSV, RMC, VTG
Output frequency	1 Hz

## 2.3. Mechanical specification

The Physical dimensions of the Leadtek 9102 GPS Module are as follow:

Items	Description
Length	15.0 ± 0.1 mm (0.59 in)
Width	14.0 ± 0.1 mm (0.55 in)
Height	2.80 ± 0.3 mm (0.11 in)
Weight	1g

## 2.4. Recommended GPS Antenna Specification

This GPS 9102 receiver is designed for use with active antenna.

Parameter	Specification
Antenna Type	Right-hand circular polarized active antenna
Frequency Range	1575.42 ± 1.023 MHz

## 2.5. Environmental Specification

Item	Description
Operating temperature rang	-40 deg. C to +85 deg. C
Storage temperature range	-55 deg. C to +100 deg. C
Humidity	up to 95% non-condensing or a wet bulb temperature of +35 deg. C
Altitude	18,000 meters (60,000 feet) max.
Velocity	515 meters/second (1000 knots) max.
Jerk	20 meters/second <sup>3</sup> , max.
Acceleration	4g, max.

## 2.6. Reference design

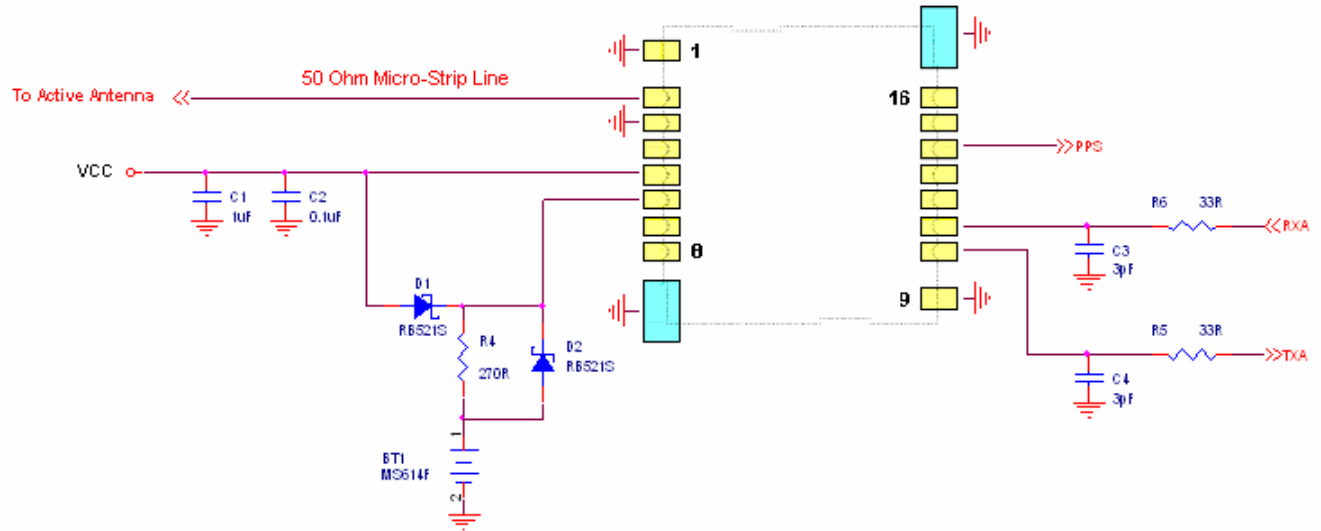

- All ground pads attach directly to ground plane by way of via.
- All components are reference only.
- The antenna input should have the proper impedance matching.

## Performance Characteristics

### 2.7. Position and velocity accuracy

<b>Accuracy</b>	Position	10 meters, 2D RMS 5 meters 2D RMS, WAAS corrected <5meters(50%)
	Velocity	0.1 meters/second
	Time	1 microsecond synchronized to GPS time

### 2.8. Dynamic constrains

<b>Dynamic Conditions</b>	Altitude	18,000 meters (60,000 feet) max.
	Velocity	515 meters/second (1000 knots) max.
	Acceleration	4g, max.
	Jerk	20 meters/second <sup>3</sup> , max.

### 2.9. Acquisition time <sup>1</sup>

Mode	Leadtek 9102 GPS Module
TTFH Hot (valid almanac, position, time & ephemeris)	1 s
TTFH Warm (valid almanac, position, & time)	35 s
TTFH Cold (valid almanac)	42 s
re-acquisition (<10 s obstruction with valid almanac, position, time & ephemeris)	100 ms

**Note 1: Open Sky and Stationary Environments.**

## 2.10. Timing 1PPS output

The 1PPS pulse width is 1  $\mu$ s, this 1PPS is NOT suited to steer various oscillators (timing receivers, telecommunications system, etc).

## 2.11. Sensitivity (According to SiRF GSC3f spec. )

Parameter	Description
Tracking Sensitivity	-159 dBm
Acquisition Sensitivity	-155 dBm

## 2.12. Battery backup (SRAM/RTC backup)

This is the battery backup supply that powers the SRAM and RTC when power is removed. To achieve the faster hot startup, a backup battery has to be connected.

## 2.13. Differential aiding

### 2.13.1. Differential GPS (DGPS) Option

DGPS specification improves the Leadtek 9102 GPS Module horizontal position accuracy to <4M 2dRMS.

### 2.13.2. Satellite Based augmentation System (WASS/EGONS) Option

The Leadtek 9102 GPS Module is capable of receive SBAS (WASS and EGONS) differential corrections. SBAS improves horizontal position accuracy by correcting GPS signal errors caused by ionospheric Disturbances, timing and satellite orbit errors.

Both SBAS and DGPS should improve position accuracy. However, other factors can affect accuracy, such as GDOP, multi-path, distance from DGPS reference station and latency of corrections.

### 3. Hardware Interface Power supply

Parameter	LR9102 GPS Module
Input voltage	3.2~ 5.0 VDC
Average supply current	49mA@3.3VDC
Battery backup voltage	1.65~5.0 VDC

#### 3.1. Specifications

##### 3.1.1. Pin Assignment

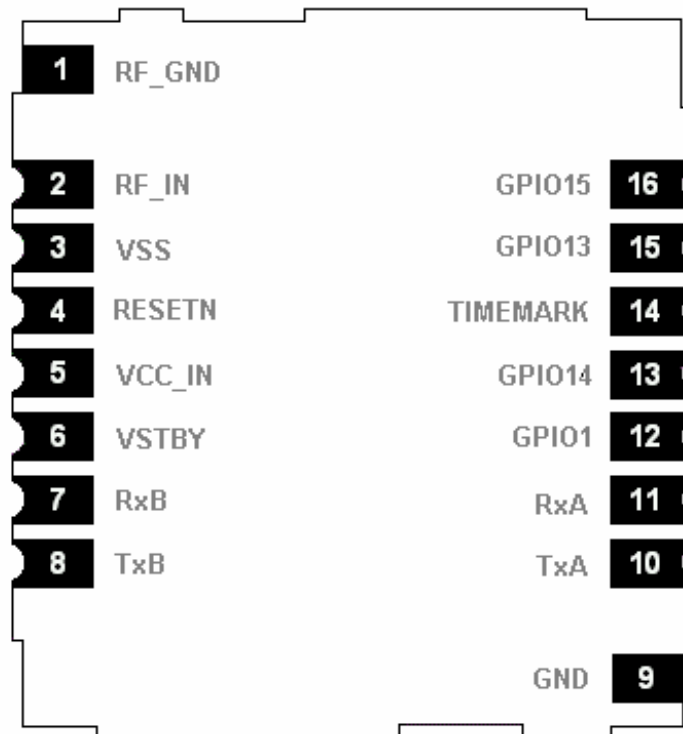

### 3.1.2. Pin Definition

PIN	Name	Type	Description
1	RF_Gnd	RF	RF Ground
2	RF_IN	RF	RF input
3	VSS	PWR	Ground
4	RESETN	I	System reset (active low); In normal operation this pad should be left floating. Active pull-up is not recommended
5	VCC_IN <sup>2</sup>	PWR	3.2 ~ 5.0 VDC input
6	VSTBY	PWR	1.65 ~ 5.0 VDC RTC backup battery supply
7	RXB	I	TTL level asynchronous input for UART B
8	TXB	O	TTL level asynchronous output for UART B
9	GND <sup>3</sup>		Ground
10	TXA	O	TTL level asynchronous output for UART A
11	RXA	I	TTL level asynchronous input for UART A
12	GPIO1	I	Reserved, general purpose IO
13	GPIO14	I	Reserved, general purpose IO
14	TIMEMARK	O	1 PPS time mark output
15	GPIO13	I	Reserved, general purpose IO
16	GPIO15	I	Reserved, general purpose IO

Note 2: This input voltage will supply external active antenna directly, please refer the antenna specifications first.

Note 3: There are two more shielding case ground pads, please refer the recommended footprint.

## 4. Software interface

The host serial I/O port of the module's serial data interface supports full duplex communication between the module and the user. The default serials are shown in Table 5-1.

Port	Protocol	Description
Port A	NMEA 0183, 9600 bps	GGA, GSA, GSV, RMC, VTG
Port B	N/A	N/A

Table 5-1 Leadtek 9102 GPS module default baud rates

### 4.1. NMEA output messages

The output NMEA (0183 v3.0) messages for the receiver are listed in Table 5-2. A complete description of each message is contained in the SiRF NMEA reference manual.

### 4.2. SiRF binary

A complete description of each binary message is contained in the Leadtek SiRF Binary Protocol reference manual.

## 5. Mechanical drawing and footprint

### 5.1. Outline Drawing

Items	Description
Length	15.0 ± 0.1 mm (590.6 ± 4 mil)
Width	14.0 ± 0.1 mm (551.2 ± 4 mil)
Height	2.80 ± 0.3 mm (110.2 ± 12 mil)

